



Protrol

Fault detection technology



Product and
applications guide

www.protrol.se



*Automation products for
the secondary substation*

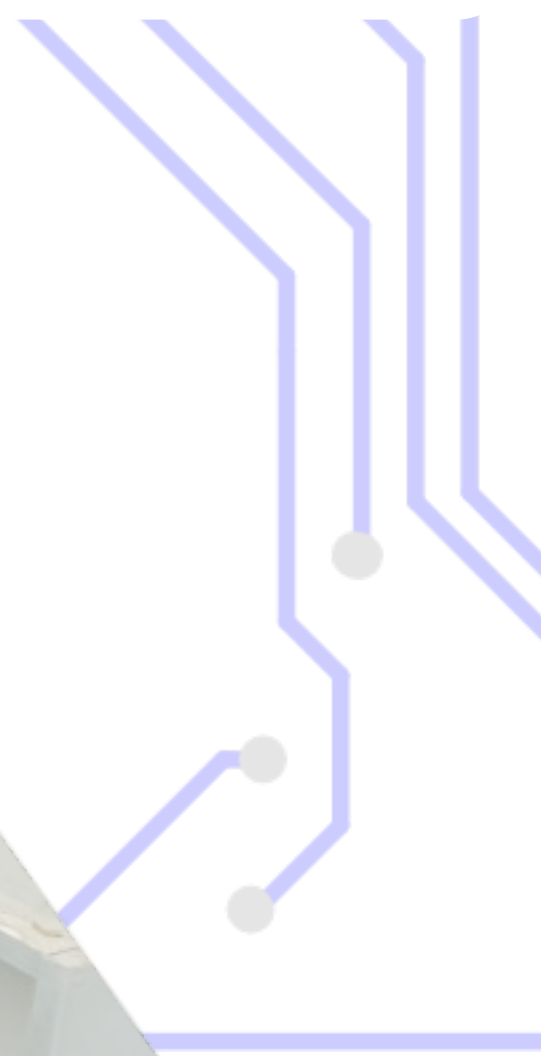

Where is the fault?

No problem, we know where!

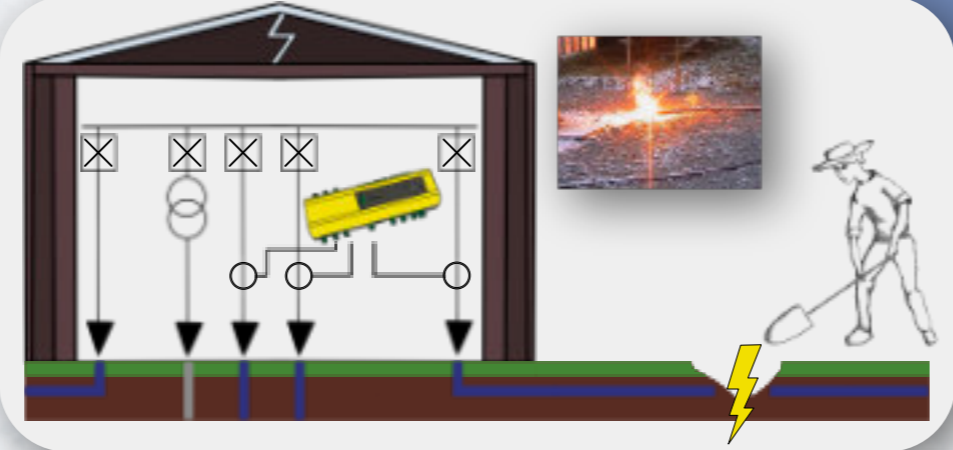
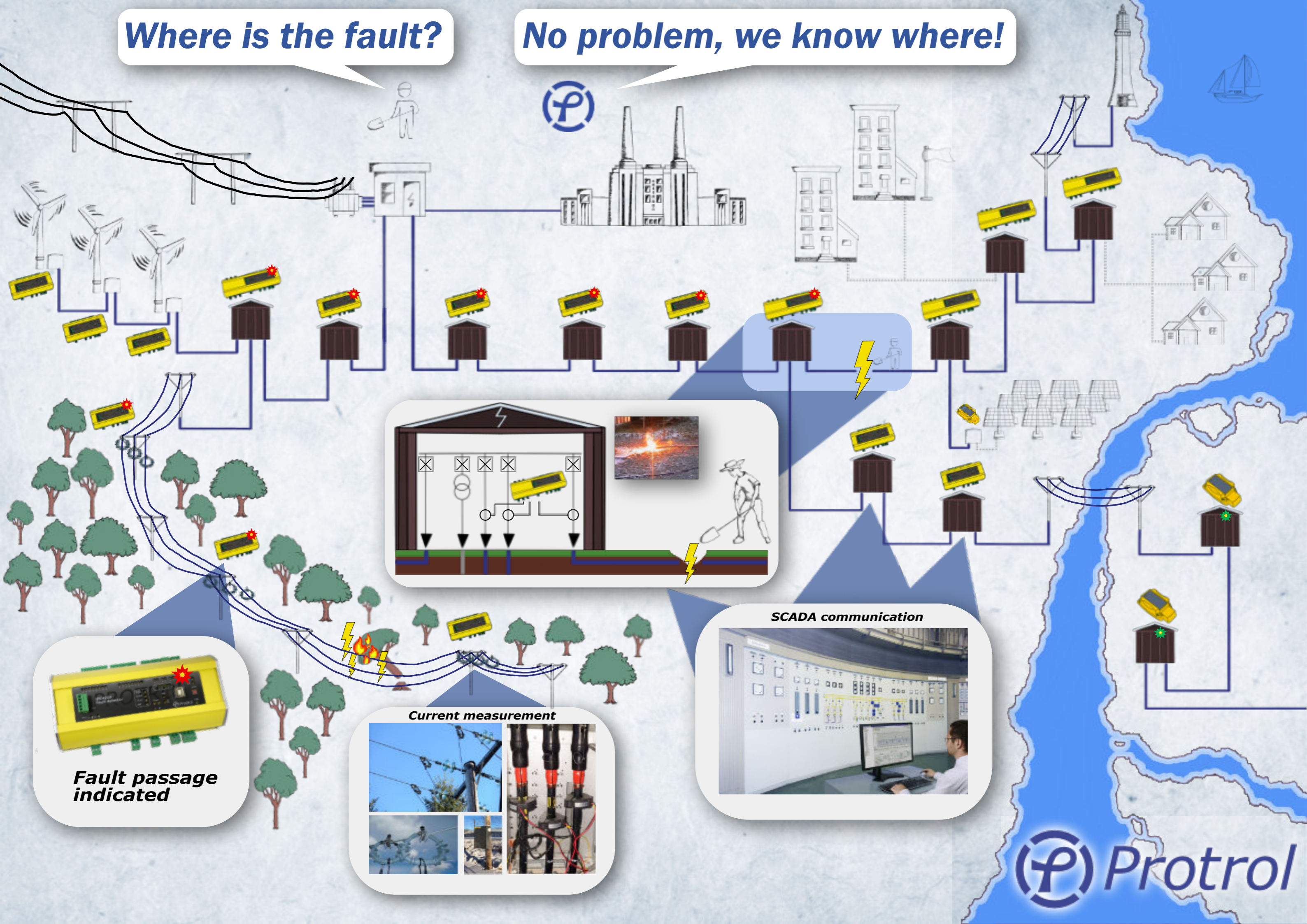

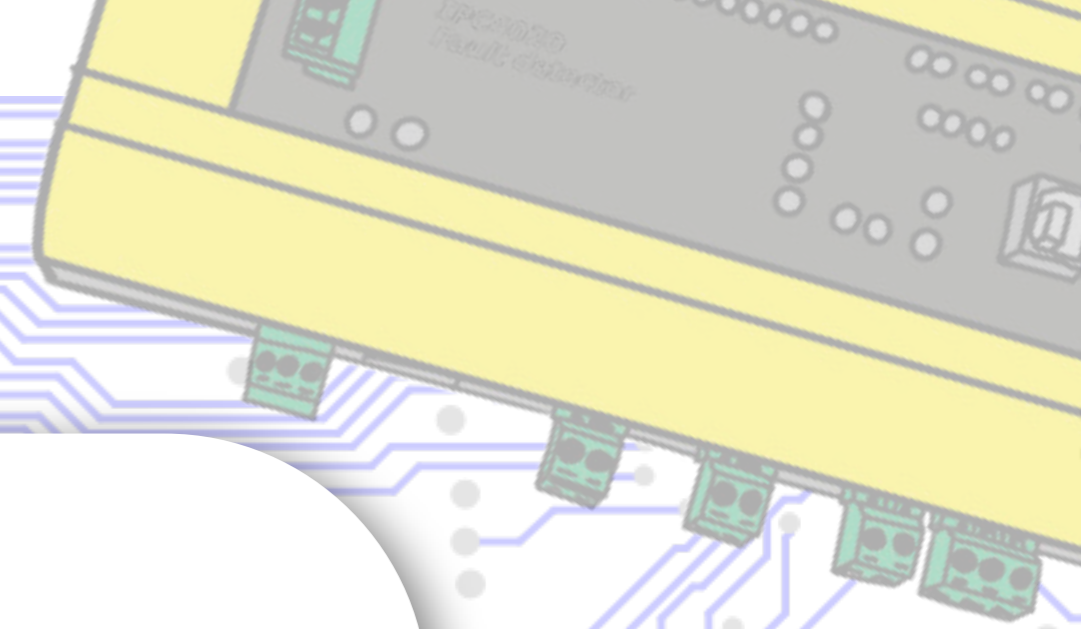

Introduction

Fault detection and network automation technology - maximising the availability of the electrical distribution grid.

Protrol fault passage indicators, FPIs, are based on a patented technology to detect earth faults in the distribution grid. The technique uses phase current measurements and requires no polarising voltage. This is a very cost effective solution for secondary substations. Earth faults – high ohmic, arcing or intermittent - that are otherwise difficult to detect are localised fast. The sensitivity is comparable to the best watt metric directional earth fault relays.

The FPIs can be applied in any type of electrical grid, cable or overhead line, ranging from low to high impedance grounded and even isolated neutral. The product program is tailor-made for reliable performance monitoring and fault detection in all electrical networks from small rural secondary substations to urban distribution centres.

“It is the only fault indicator of its kind I’ve seen that works flawlessly. It is everything you need in the secondary substation”

Typical FPI applications are

- ◆ **Standalone type with local LED or relay contact indication**
- ◆ **Monitoring and control in open loop networks**
- ◆ **Active isolation of faulty radial feeder**
- ◆ **Fully automated fault isolation and power restoration**

Standalone with local indication

The IPS type of FPI is the simplest application with local visual indication by an LED. When the line is de-energized by the line breaker in the primary substation, the IPS will start flashing the LED. The LED will become red if the fault current has passed or green if it has not passed. The IPS does not require any backup power, as it stores energy itself to flash for 24 hours. There is also a version with relay contact indication available.

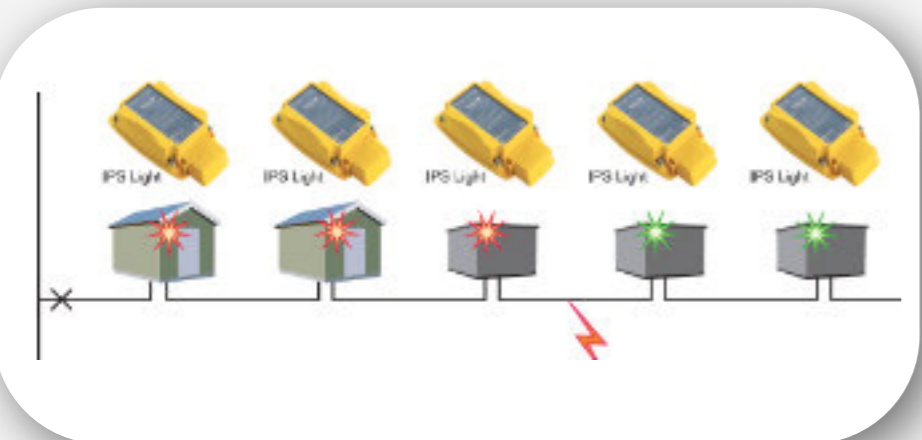

Active isolation of faulty radial feeder

The Protrol FPI can act as a relay protection to extend the selective tripping beyond the primary substation. This is particularly useful in secondary substations where the downstream section is an overhead line and there is no voltage transformer available to measure the neutral voltage. The FPI can detect faults and trip the line breaker, isolating the faulty section and minimising damage to the system.

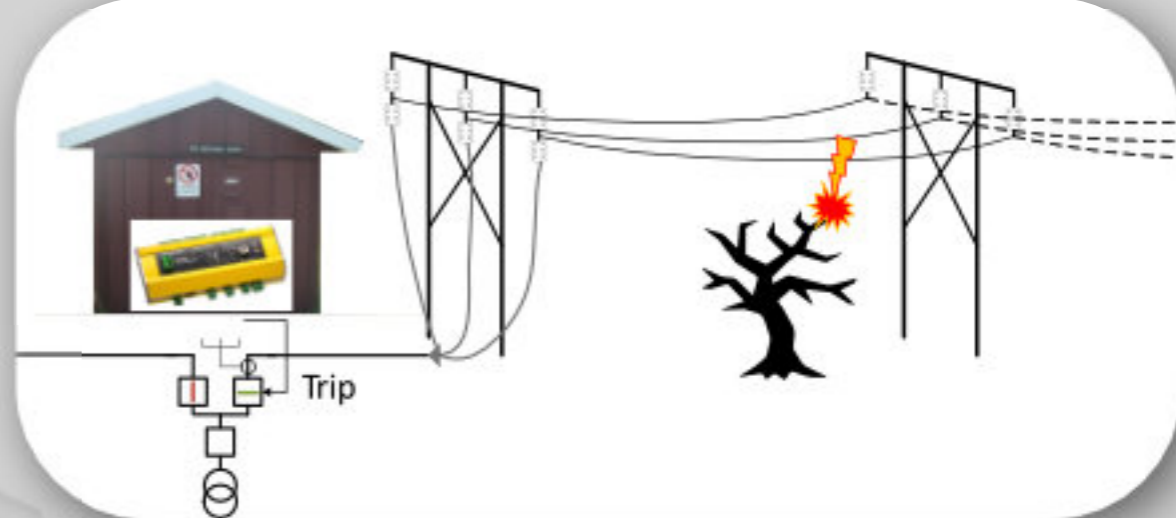

FPI applications

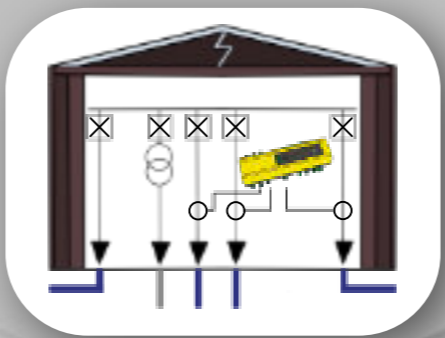

Monitoring and control in open loop networks

The IPC402x is everything you need for the secondary substation that really will impact your SAIFI and SAIDI figures. With communication to SCADA and remote control, the faulty section is safely isolated and the outage time is reduced from hours to minutes.

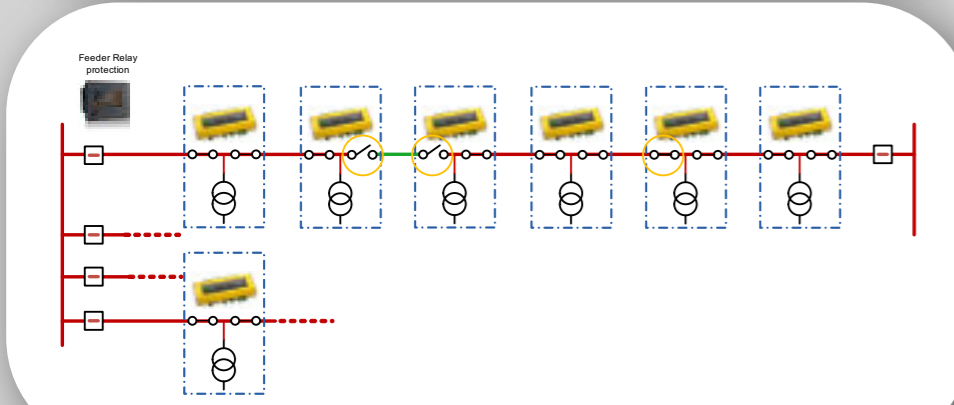
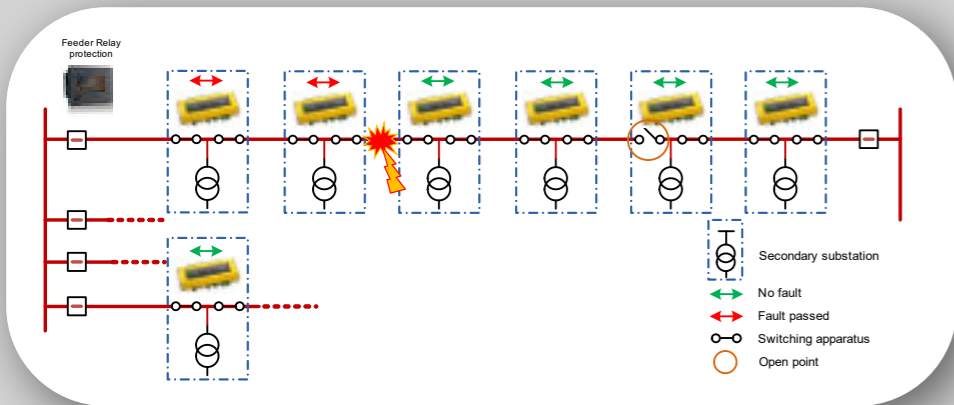

- ↔ No fault
- ↔ Fault passed
- ⊗ Switching apparatus
- Open point

Fully automated fault isolation and power restoration

In open loop and radial configurations, the Protrol FPIs, IPC402x, can automatically isolate the faulty section and restore the power. Depending on the type of communication media this can be done almost immediately if the communication delay is short. Each unit communicates with its closest neighbour to determine the fault location. The Ethernet communication can be with optical fiber or wireless like 4G.

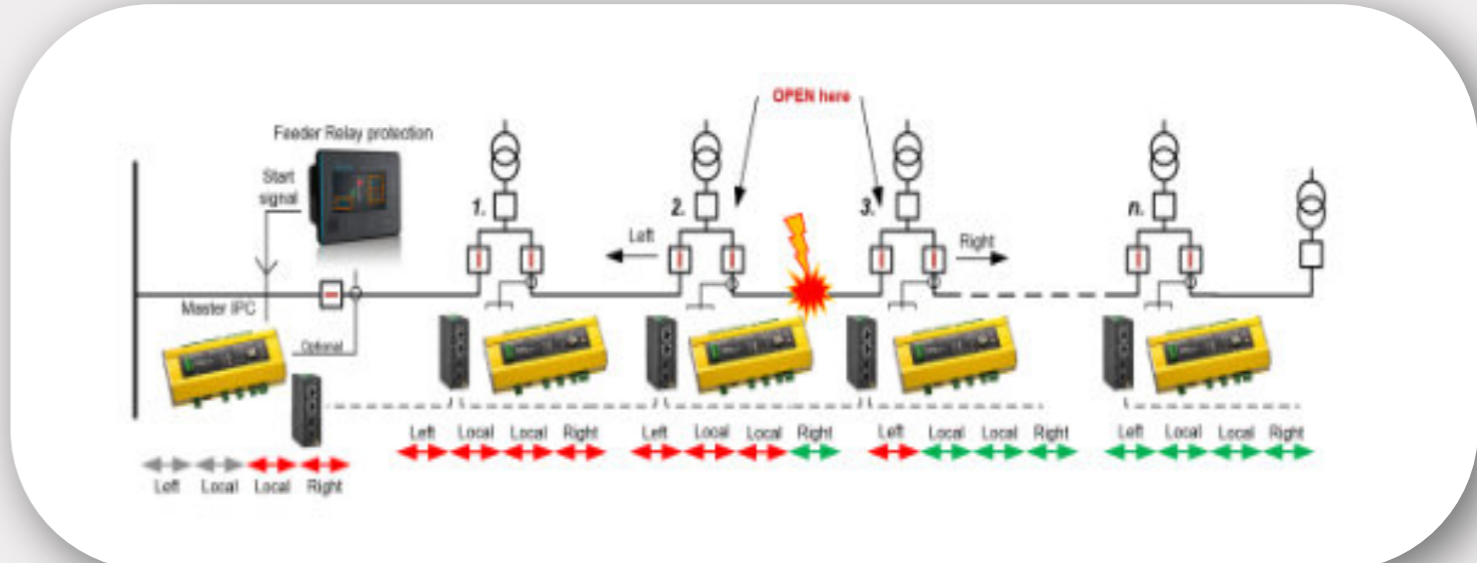

Fully automated fault isolation and power restoration

The Protrol IPC402x FPIs can be used to create a fully distributed Fault Location, Isolation, and Service Restoration (FLISR) system, where the devices autonomously can isolate the faulty section and restore power in open loop and radial configurations. The advantages are many. No need of a higher level system for the decision making increases speed and availability. The speed of the isolation and restoration depends on the type of communication media used. If the communication delay is short, the process can be completed almost immediately. Each unit communicates with its closest neighbour to determine the fault location.

The faulty section is localised by the IPC4020 unit upstream the fault whose neighbour downstream has not seen the fault, and conversely for the unit downstream the fault. If there is ONE open point in the loop it can be closed automatically to restore the power. The function and decision are fully distributed to the IPC unit in the secondary substation. No centralised application is required. It can be activated already with only three units in the loop. One of the units in the loop act as master. It supervises that all units are running, and it also keeps track of the location of the open point in the loop.

If the switching device in the secondary substation is not permitted to break the fault current, or if the communication delay can be longer than the preferred fault clearing time, the switching sequence will wait until the line is de-energised by the line breaker.

After isolation of the faulty section the line is automatically reclosed. If required, earth faults and short-circuit faults can be treated differently. E.g., the earth fault current is small in impedance grounded systems and there is usually time enough to wait a while with the decision to disconnect the entire feeder or not.

The feeder relay protection can be used to release the function by its starting contact. If this option is chosen the automatic sequence will only commence if the relay protection has started.

The current can be measured on one or both sides of the secondary substation. If measured on both sides the busbar fault is selectively detected and isolated. A configuration with only one switching device in the secondary substation, such as a line recloser or disconnecter, is also covered.

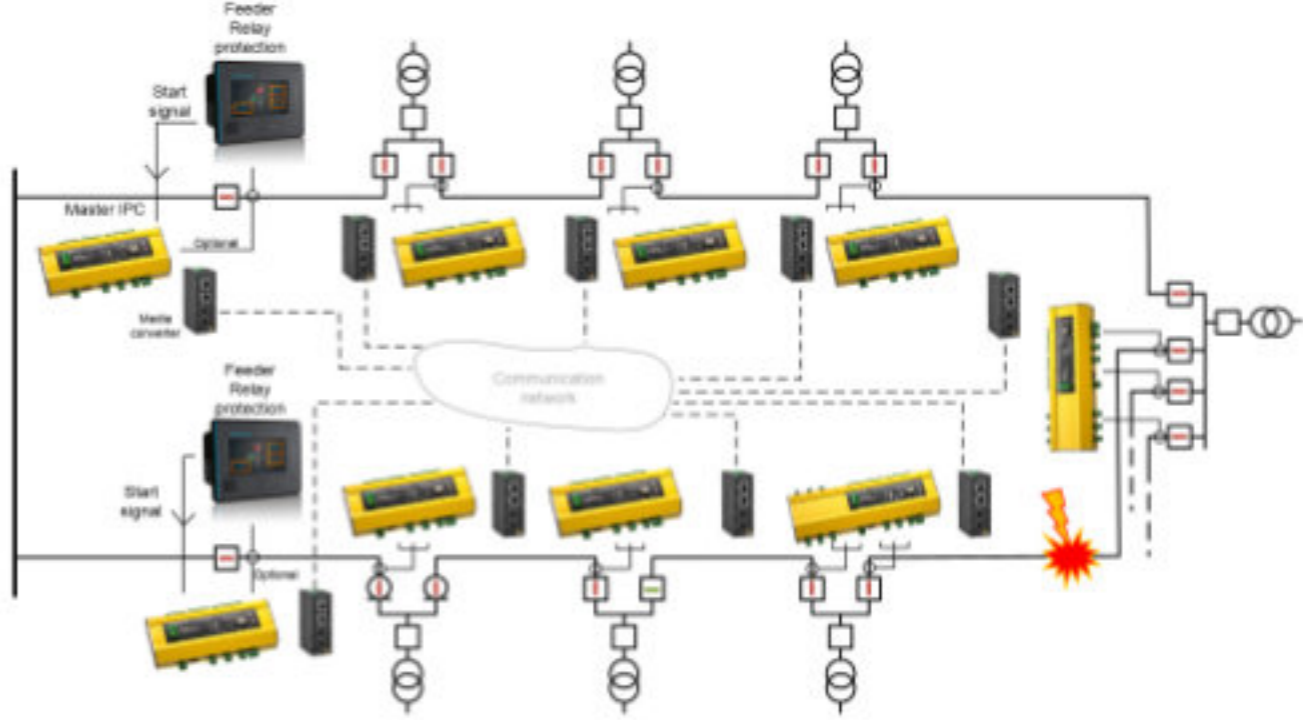
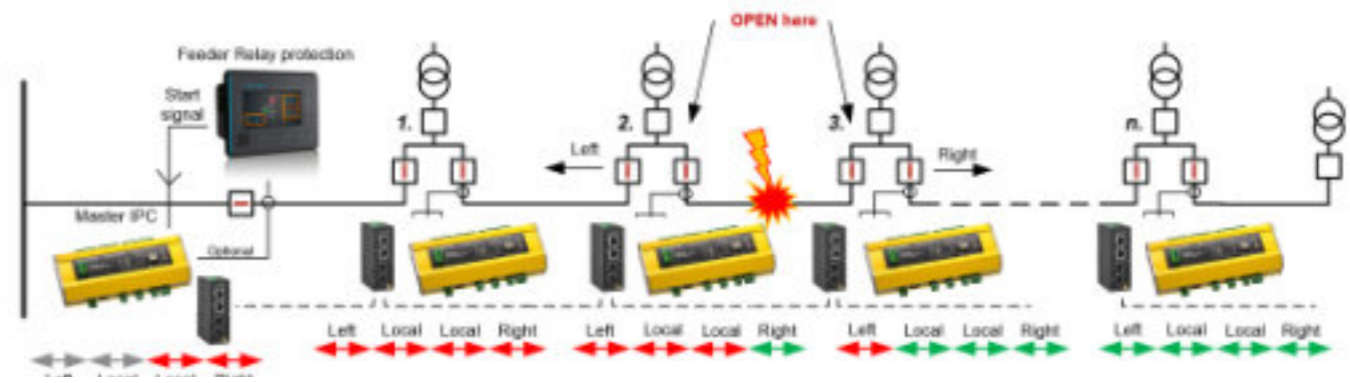

- Immediate fault clearing:**
 Detect fault passing through.
 Determine the status of the neighbours to decide fault location.
1. Open upstream fault
 2. Open downstream fault
 3. Close OPEN POINT

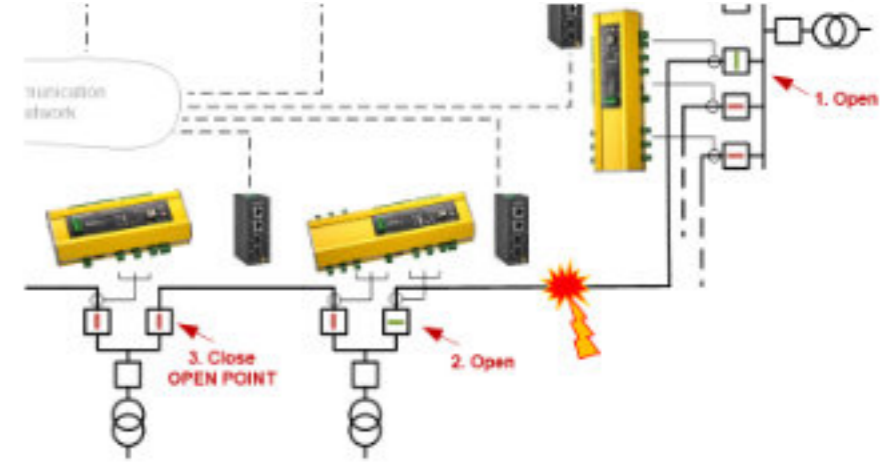

- Delayed action**
 Fault clearing by the feeder breaker when the closest upstream switch can not break the fault current or when the communication delay is too long.
1. Trip feeder
 2. Open downstream fault
 3. Close OPEN POINT
 4. Open upstream fault
 5. Reclose feeder

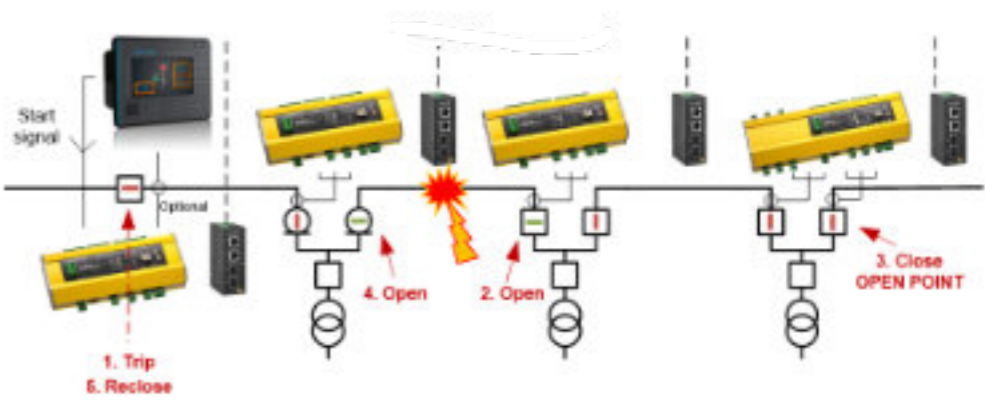

"The fastest FLISR application ever!"

Monitoring and control in open loop networks

In the open loop network, the philosophy is to always have a backup path to feed the power after isolating a faulty section. The way to accomplish this is safe and accurate fault detection and remotely controlled switchgear. The IPC402x does everything.

The IPC402x is tailor made for the application of acting as FPI and RTU in the secondary substation. Connected to the SCADA system it offers everything that you need to monitor the medium voltage network. This is the most common application for IPC402x. It will point out the fault location for any fault. It will not indicate along the healthy lines or downstream the fault location.

Using remote control and a reliable fault passage indication in combination is the one

thing that really will improve the SAIDI and SAIFI figures. The outage time goes from hours to minutes. There will be no need to test back and forth if the fault already has been isolated. The risk of energising with the fault still present is removed and thereby the stress on equipment is minimised: The possible damage to customer's equipment at the low voltage level is thus also minimised.

The Protrol FPIs are independent of the feeding direction and the tuning of the Petersen coil.

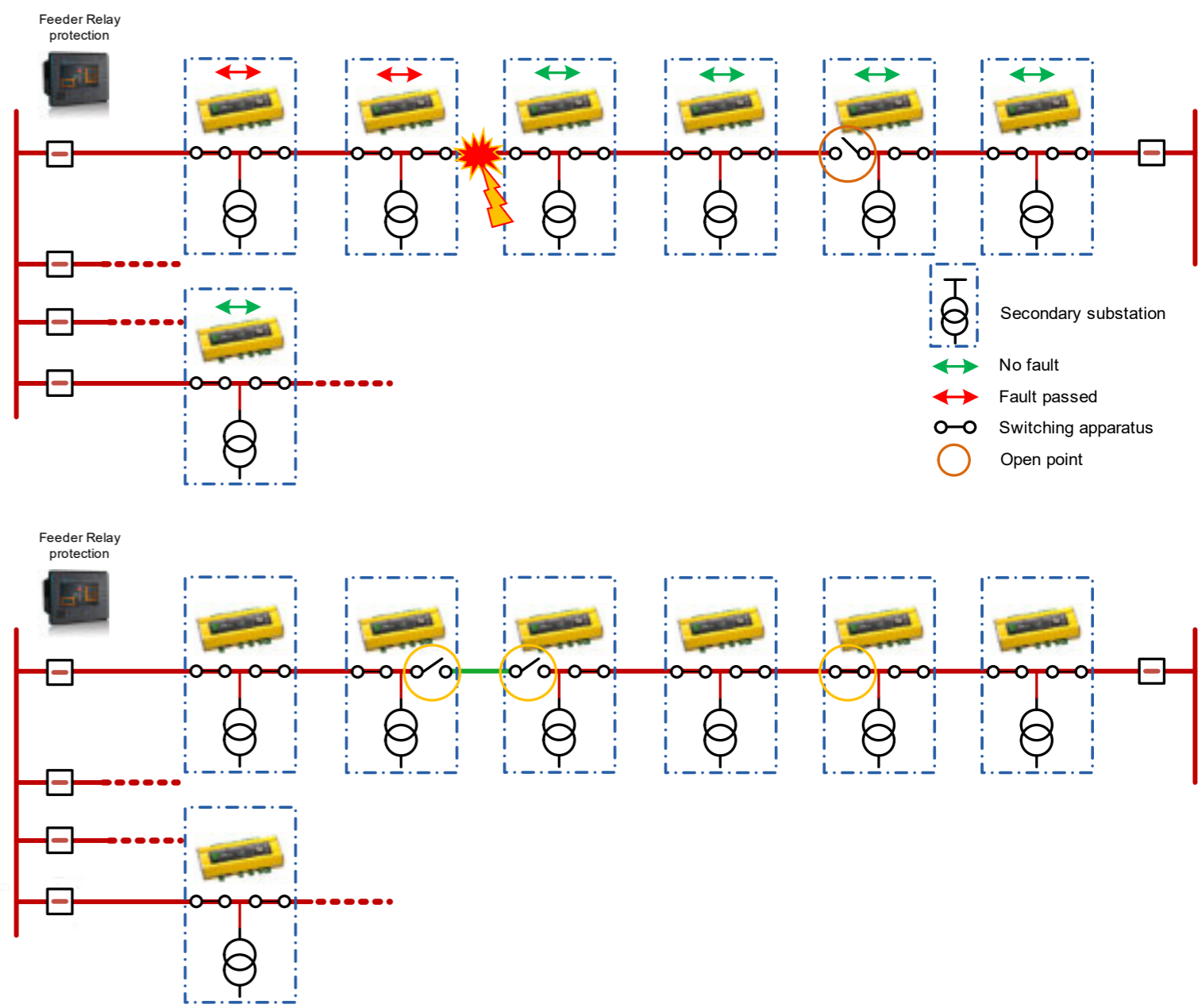

“The outage time goes from hours to minutes”

Investment with *return*
– for the *society, customers and the DSO*

Our society’s dependence on reliable power supply is steadily increasing, and thereby also the demands on the DSOs. Power outages are expensive – both directly and indirectly. Many countries have regulations which intentions are to facilitate investment in new technology in the electrical distribution network. These regulations vary from country to

country, but in general they increase the revenue cap for the DSO. In the end this shall be beneficial for the society, customers as well as for the DSOs. A robust and flexible electrical distribution network with minimum outage time is essential for the future. Protrol’s automation technology products is the investment that gives immediate return.

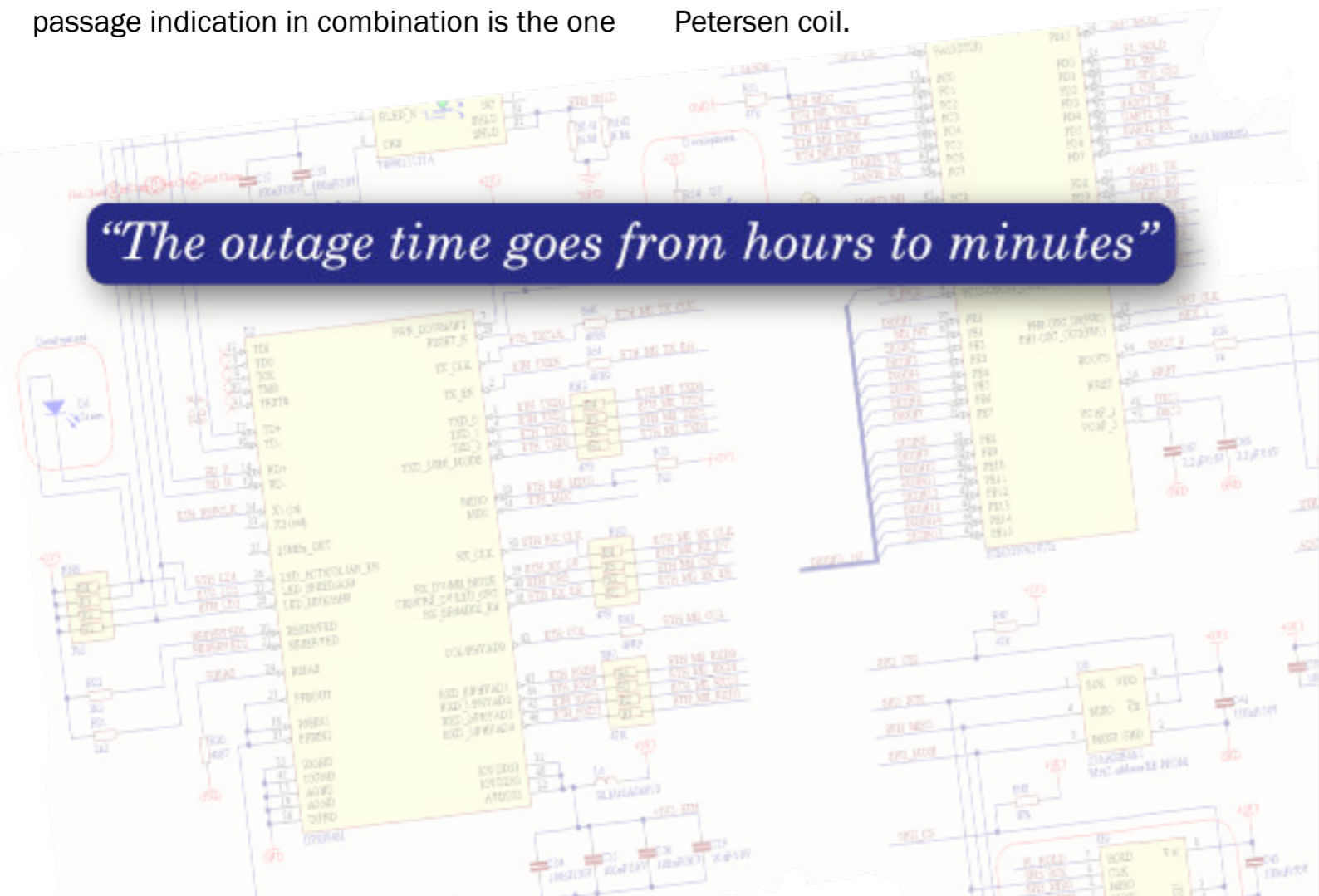

Earth fault field testing

- a real case

The way to be confident that the fault detection is really working all the way from the current transducer to the SCADA is to make a real high ohmic fault test. True fault passage indication for earth faults implies that the FPI shall indicate when it is located upstream the fault, but never for the capacitive zero sequence current generated by the healthy lines or branches. There shall be no doubt about the location of the fault, and the FPI shall prove to have higher sensitivity than the protection relay in the feeding primary substation.

The single line diagram to the right shows a real earth fault test in a rural network. For each section, the cable type and length in meters are displayed. FPIs are installed in all secondary substations where the fault current can pass. In stations with one incoming and one outgoing feeder, the FPI is installed in one of the feeders. If there are more than two feeders in the station, the FPIs are installed in 2-out-of-3, 3-out-of-4, etc. The FPI will not indicate if located on the healthy branches or downstream the fault location counting from the primary substation.

The earth fault test is the best way to test the whole chain of measuring - detecting - communication - SCADA implementation. Other types of faults can be tested with suitable methods, including arcing or intermittent faults. The typical test should prove that the FPIs have higher sensitivity than the directional earth fault relay in the primary substation. This way, you can always be certain that the Protrol FPIs have seen the fault when the earth fault relay has tripped the line.

“One hundred percent, like a clockwork”

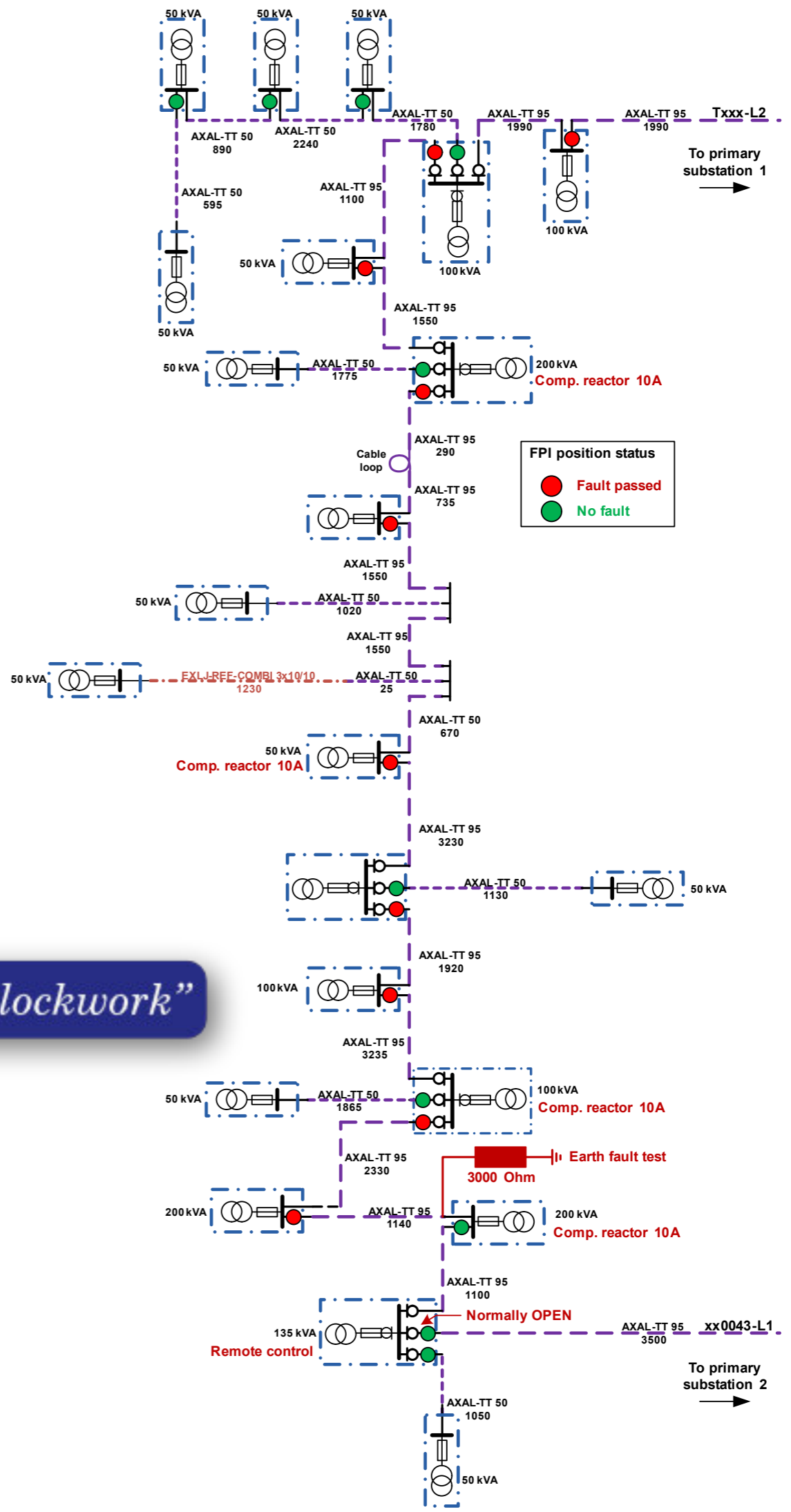

Ethernet communication, wired or fiber network

- ◆ The IPC402x and PDC2 devices are equipped with an Ethernet interface for communication with SCADA systems as well as for service and maintenance purposes.
- ◆ Protrol devices can be ordered with encryption features such as HTTPS for the web interface and TLS for the IEC 60870-5-104 protocol.
- ◆ To ensure network protection, an advanced switch/router with a firewall can be used.

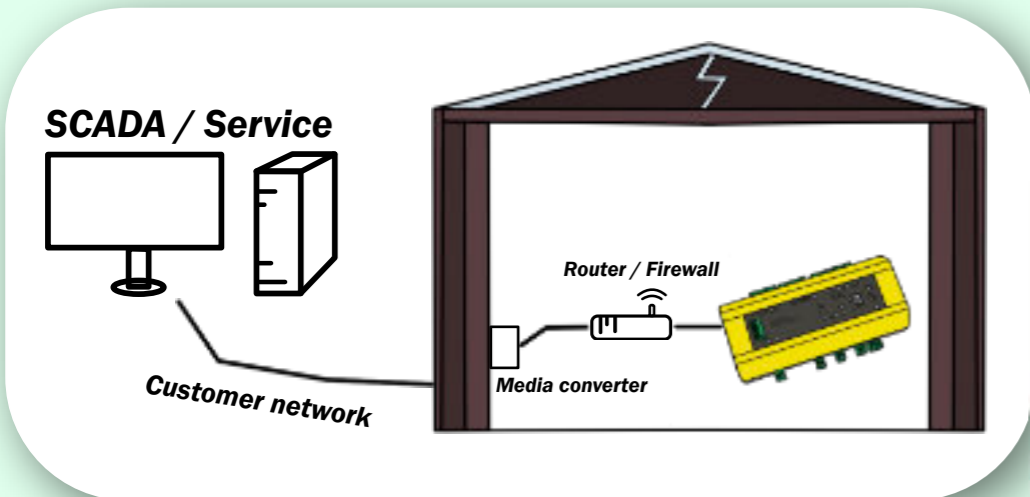

Local indication only

- ◆ IPS standalone FPI, only local indication on device or using external LED unit.



Wireless communication, radio

- ◆ There are several solutions for communication over radio, including LoRaWAN, Raket, and other customer-owned systems.
- ◆ Protrol offers its own PxL modem for LoRaWAN communication with IPC402x devices.
- ◆ Protrol's products are compatible with different radio modems from various manufacturers.
- ◆ Some customers communicate via a Raket system, using an IPC402x and a Raket modem.

Secondary substation communication

Signal cable, serial communication

- ◆ All IPC402x products have an integrated RS485 short range modem for remote control (IEC 60870-5-101) via control cables.
- ◆ To safeguard against external electrical transients, an overvoltage protection (OVP) is recommended for the devices.
- ◆ For larger networks, the use of a long-range serial modem, LSR, is recommended. The LSR modem can be utilized as a splitter or repeater to divide or extend the reach of the communication signal.

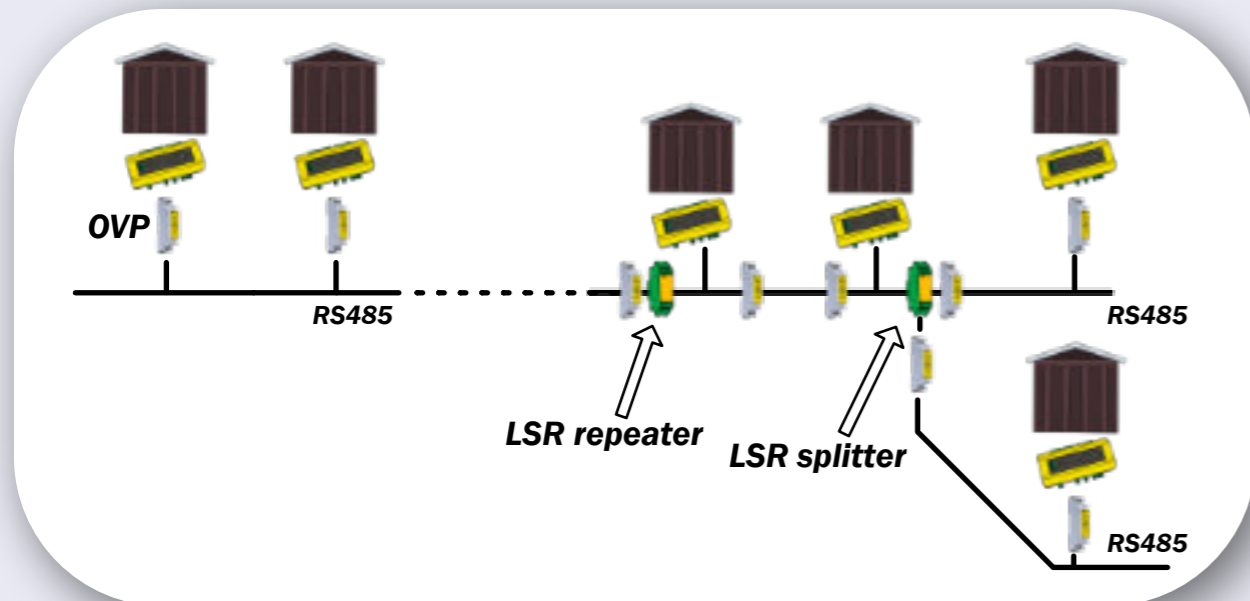

Wireless communication, mobile network

- ◆ The IPC402x devices can communicate wirelessly via a modem or router with mobile network functions.
- ◆ A VPN solution can be used to secure the communication link.

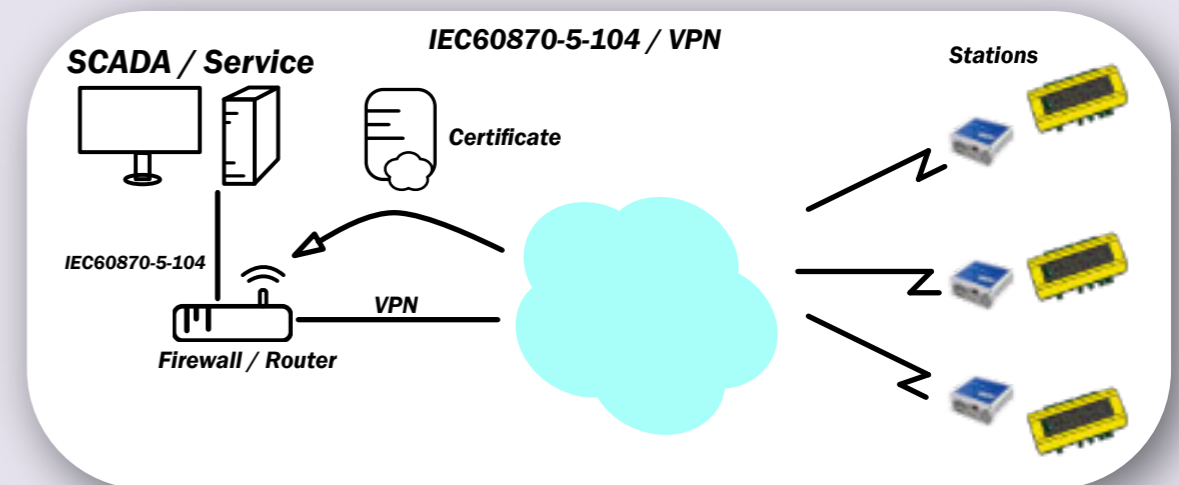

Products



IPC402x - Advanced connected FPI



The IPC family of advanced fault passage indicators combines our well-established fault detection technology with traditional RTU functionality. Depending on the complexity of the secondary substation, the IPC devices can monitor and control one or several bays using standard communication

protocols, such as IEC 60870-5-101 and IEC 60870-5-104. In addition to traditional remote control, the binary inputs and outputs can be used for fast fault disconnection and optional advanced automation functions, which minimise downtime.

“Earth faults, our expertise”



◆ Earth fault detection

The IPC402x devices have two types of earth fault detectors - Protrol's patented detection technology, and a complementary non-directional earth fault function that can be employed when switching onto faults. The non-directional function can also be used to detect incorrect installation, that a phase is missing or has wrong polarity. Both methods work independently of each other.

Protrol's method for earth fault detection is based on transient analysis, which makes it both fast and sensitive to high impedance and arcing faults. The patented algorithm evaluates the change of the phase currents when an earth fault occurs. Detection of a fault

means that the fault is downstream of the measuring point in a radial network. Or in other words, that a fault current has passed the measuring point, also called true fault pass-through detection. This means that the direction of the fault can be identified by measuring phase currents only, without the need of polarizing zero sequence voltage.

The method works accurately for all types of networks, ranging from directly grounded to isolated. In particular, for an impedance grounded network, the compensation degree is insignificant, and for an isolated network, the natural unbalance between the phases can be nearly infinite.

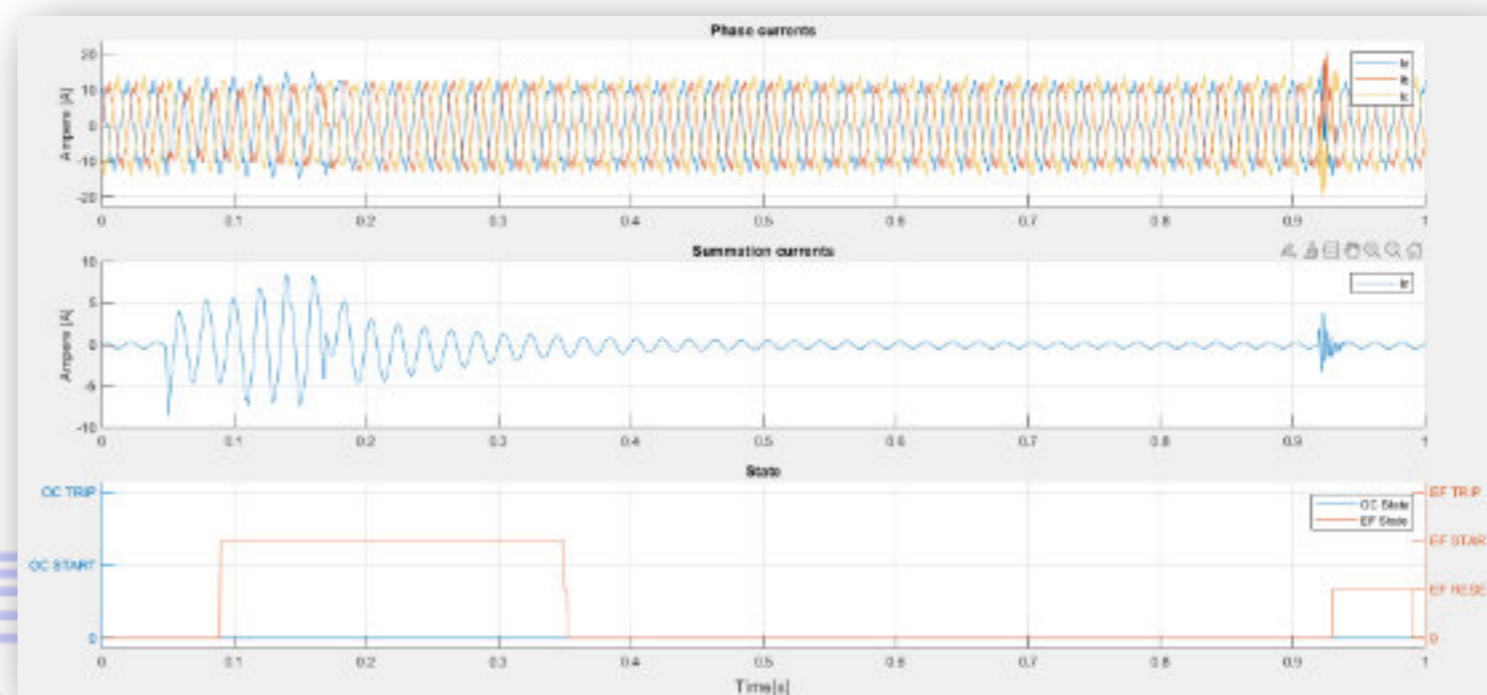

Overcurrent detection

IPC402x has two overcurrent steps with adjustable delay time that operate independently of each other. The overcurrent function measures the RMS values of all phases. For step 1, IEC inverse time characteristics can be chosen instead of definite time delay.

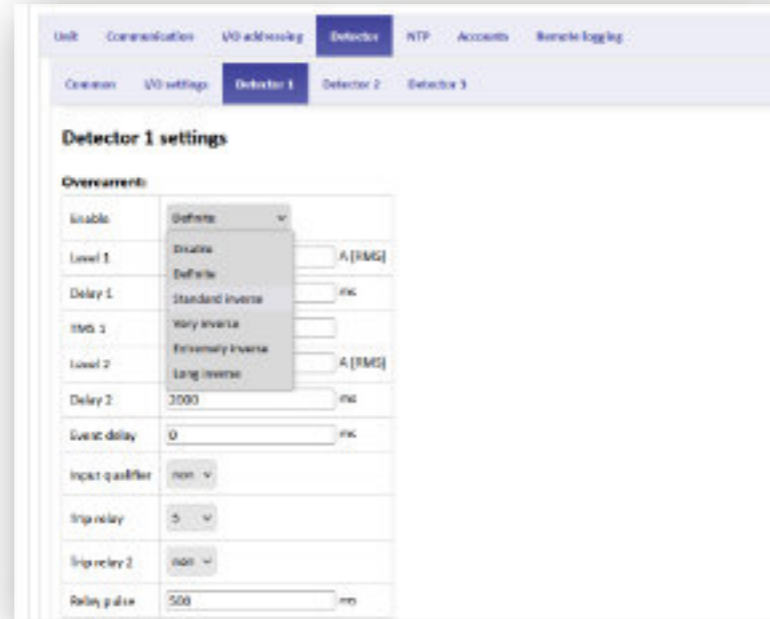
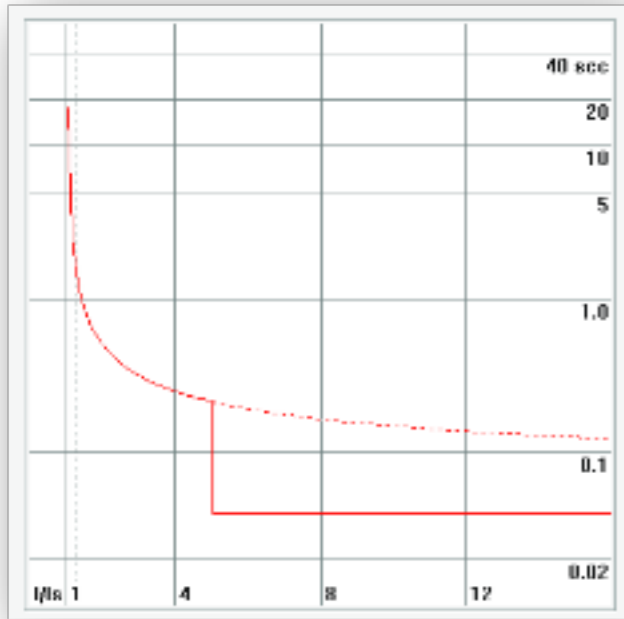

Event recorder

Events that originate from the fault detection functions, communication, or device supervision are stored to support commissioning and fault analysis.

Phase break detection

A phase break is identified as the loss of a phase current without grounding. A typical scenario involves the interruption caused by a fallen phase conductor that does not make electric contact with ground.

Protrol IPC4020exp3 - Kvarnen

Start Config **Status** System

Event log Site manager TFR data

Event log

Add dummy entry and update log Delete all entries

Timestamp	Type	Text	Extra information
2023-04-11 9:33:26.803 (NS)	Debug	104 slave - Connected to Scada system {STARTDT received}	0, 0, 0, 0
2023-04-11 9:33:43.450 (NS)	Debug	EF Started	1, 120254, 2072, 0
2023-04-11 9:33:43.750 (NS)	Debug	EF Detected	1, 6, 1, 0

Transient fault recorder

The integrated transient fault recording function registers currents and events from the last detected faults. It is possible to analyse signals and events in detail. The transient fault recordings are downloaded using the integrated web interface and can be analysed offline using Protrol TFR Plotter. If needed, the recordings can be acquired in COMTRADE format.

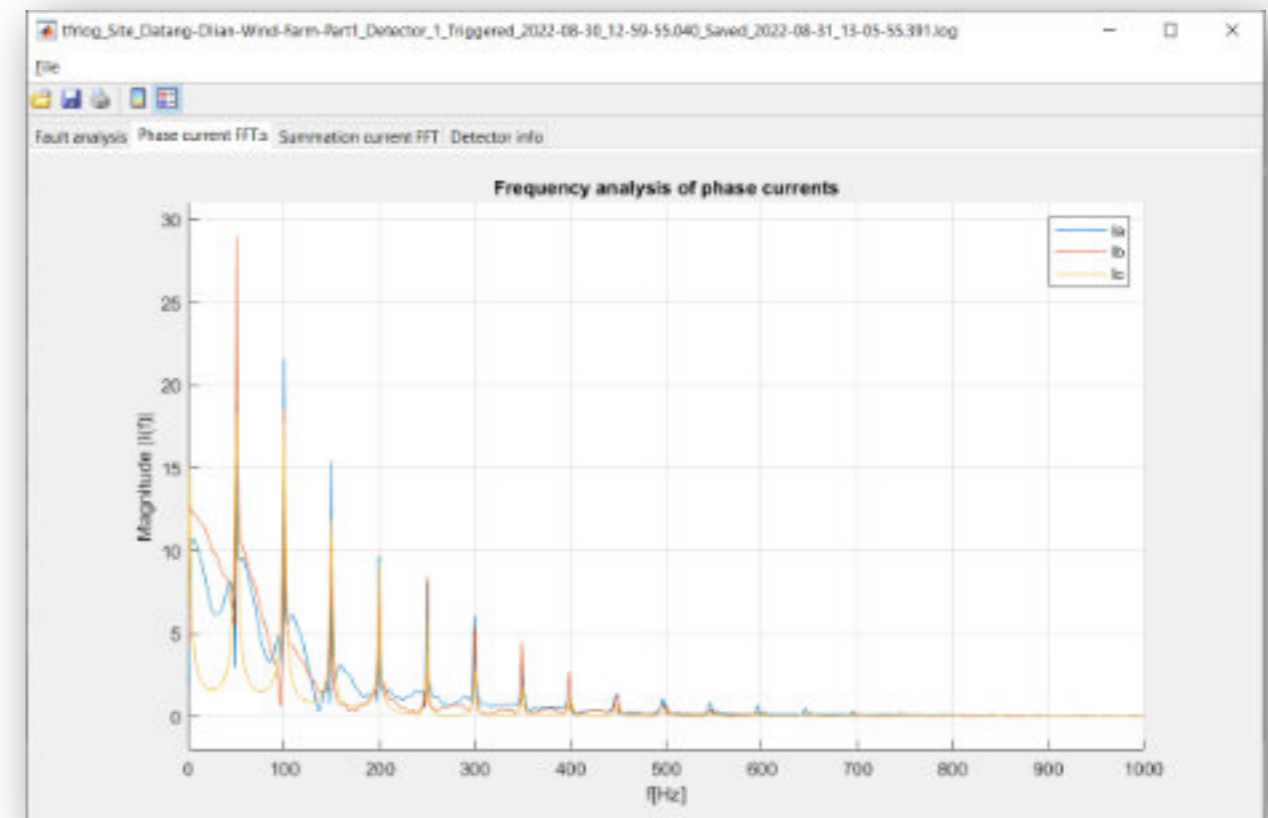
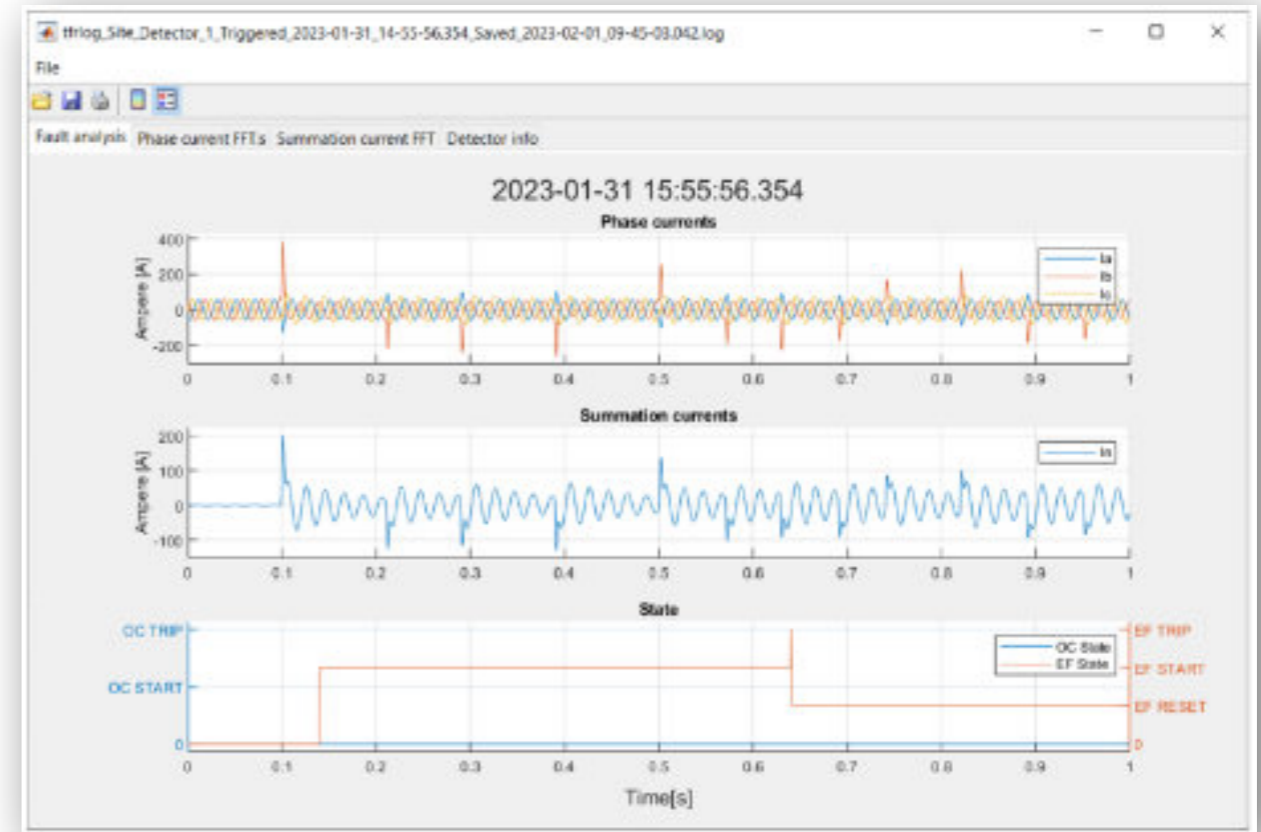

Web interface

The IPC4020 device has a built-in web interface for local and remote access using TCP/IP. This interface enables the user to access status information and to configure the device. The Site

manager feature gives real time device information and is useful during commissioning. It is also possible to upgrade firmware and download transient fault recordings.

Protrol IPC4020exp3 - Kvarnen

Start Config **Status** System

Event log **Site manager** TFR data

LED indicators:

EVT	AUX	EF	OC	EX1	EX2	EX3	EX4	IRF
●	●	●	●	●	●	●	●	●

Physical inputs and outputs:

	16	15	14	13	12	11	10	9	8	7	6	5	4	3	2	1
Inputs	●	●	●	●	●	●	●	●	●	●	●	●	●	●	●	●
Outputs									●	●	●	●	●	●	●	●

Enable manual control of outputs

Acknowledge unit:

Acknowledge fault indications

Analog values:

Unit temperature **23 °C**

Analog currents:

	Detector 1	Detector 2	Detector 3
L1	300.3 A	0.0 A	0.0 A
L2	0.0 A	0.0 A	0.0 A
L3	0.0 A	0.0 A	0.0 A
LN	300.33 A	0.01 A	0.02 A
Max fault	300 A	0 A	0 A
Max	0.0 A	0.0 A	0.0 A

Protrol IPC4020exp3 - Kvarnen

Start Config Status **System**

Detector status:

	Detector 1		Detector 2		Detector 3	
	Trip	Status	Trip	Status	Trip	Status
Earth fault	●	●	●	●	●	●
Overcurrent	●	●	●	●	●	●
Phase break	●	●	●	●	●	●

Function status:

IRF	●
Expansion	●
IEC 60870-5-101 slave	●
IEC 60870-5-104 slave	●
IEC 60870-5-101 master	●
Ethernet interface	●
IPC4020 temperature	23 °C

Expansion status:

Expansion	Status
Connection	●

Software version:

Module	Software version
IPC4020	1-2.3.0.a1
Loader	(AB)1-0.5.0
PDC SW ver	

◆ Protrol Device Manager

Protrol Device Manager is a centralised tool which collects information from and configure parameters stored in the installed base of IPC devices. It also enables individual or batch upgrades of new firmware. Device Manager scans the network for devices and presents the results to the administrator for further actions.

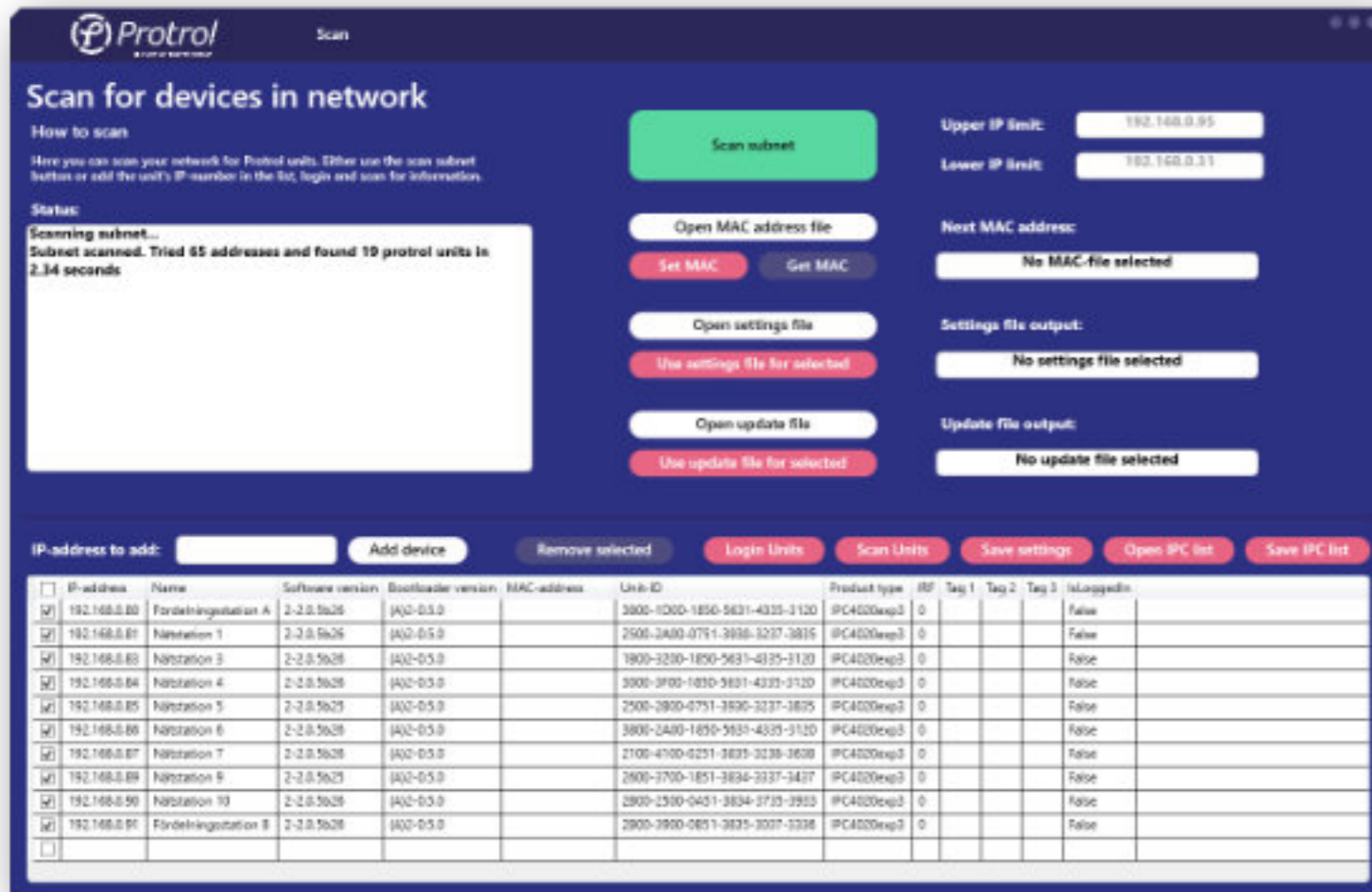

Scan for devices in network

How to scan
Here you can scan your network for Protrol units. Either use the scan submit button or add the unit's IP-number in the list, login and scan for information.

Status
Scanning subnet...
Subnet scanned. Tried 65 addresses and found 10 protrol units in 2.34 seconds

Upper IP limit: 192.168.0.95
Lower IP limit: 192.168.0.31
Next MAC address: No MAC-file selected
Settings file output: No settings file selected
Update file output: No update file selected

Buttons: Scan submit, Open MAC address file, Set MAC, Get MAC, Open settings file, Use settings file for selected, Open update file, Use update file for selected, Add device, Remove selected, Login Units, Scan Units, Save settings, Open IPC list, Save IPC list

<input type="checkbox"/>	IP-address	Name	Software version	Bootloader version	MAC-address	Unit-ID	Product type	RF	Tag 1	Tag 2	Tag 3	IsLoggedIn
<input checked="" type="checkbox"/>	192.168.0.80	Fördelningstation A	2-2.0.5a26	1A02-03.0		3800-1000-1850-5631-4335-3120	IPC4020exp3	0				False
<input checked="" type="checkbox"/>	192.168.0.81	Närstation 1	2-2.0.5a26	1A02-03.0		2500-2A80-0751-3838-3237-3835	IPC4020exp3	0				False
<input checked="" type="checkbox"/>	192.168.0.82	Närstation 2	2-2.0.5a26	1A02-03.0		1800-3230-1850-5631-4335-3120	IPC4020exp3	0				False
<input checked="" type="checkbox"/>	192.168.0.84	Närstation 4	2-2.0.5a26	1A02-03.0		3800-3F00-1850-5631-4335-3120	IPC4020exp3	0				False
<input checked="" type="checkbox"/>	192.168.0.85	Närstation 5	2-2.0.5a26	1A02-03.0		2500-2800-0751-3838-3237-3835	IPC4020exp3	0				False
<input checked="" type="checkbox"/>	192.168.0.86	Närstation 6	2-2.0.5a26	1A02-03.0		3800-2A80-1850-5631-4335-3120	IPC4020exp3	0				False
<input checked="" type="checkbox"/>	192.168.0.87	Närstation 7	2-2.0.5a26	1A02-03.0		2100-4700-0251-3838-3238-3838	IPC4020exp3	0				False
<input checked="" type="checkbox"/>	192.168.0.88	Närstation 8	2-2.0.5a26	1A02-03.0		2800-3700-1851-3838-3237-3437	IPC4020exp3	0				False
<input checked="" type="checkbox"/>	192.168.0.90	Närstation 10	2-2.0.5a26	1A02-03.0		2800-2500-0401-3838-3733-3933	IPC4020exp3	0				False
<input checked="" type="checkbox"/>	192.168.0.91	Fördelningstation B	2-2.0.5a26	1A02-03.0		2800-3800-0851-3838-3037-3338	IPC4020exp3	0				False

◆ IPC402x is available with additional features

◆ Master for 60870-5-101

The IPC4020 can function as a local IEC 60870-5-101 master device. With this optional feature enabled it is possible to connect several -101 slaves to IPC4020 and access them from the remote control centre.

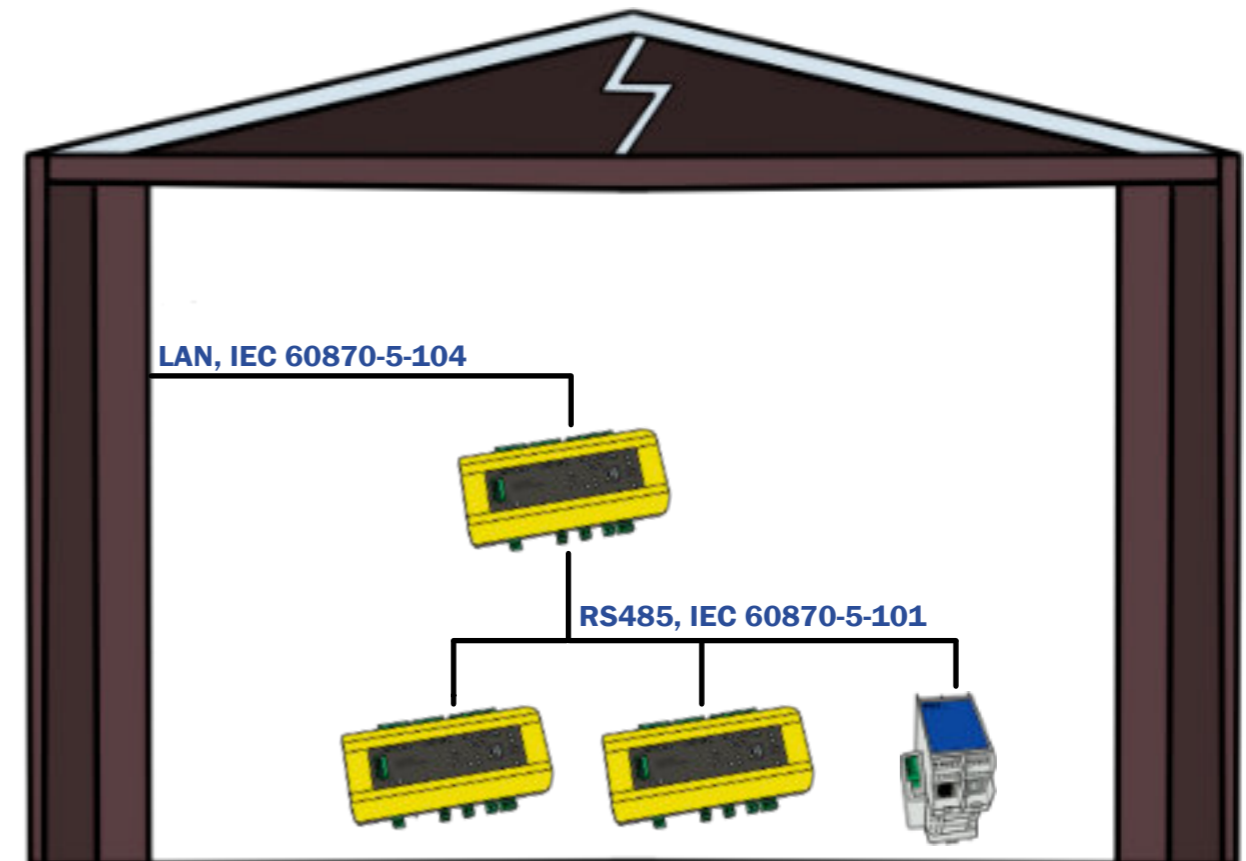

◆ Auto-reclosing function

Auto-reclosing is a delayed close order initiated by the trip of the circuit breaker after a fault.

◆ Fully automated fault isolation and power restoration

The Protrol FPIs, IPC402x, can be supplied with the option to automatically isolate the faulty section and restore power in open loop and radial configurations. Each unit communicates with its closest neighbour to determine the location of the fault.

IPC402x



◆ IPC4020

Product Code: *PT101140*

Fault passage indicator. 16 binary inputs, 8 binary outputs.

Three phase current inputs, 1 A. Power supply 24-48 V DC.

Options: IEC 60870-5-101 master, auto-reclosing and advanced automation functions.

Advanced FPI and RTU

Protrol's patented earth fault detection

Non-directional earth fault detection

Overcurrent detection

Phase break detection

Transient fault recorder

RTU protocol IEC60870-5-101/-104

Integrated web interface

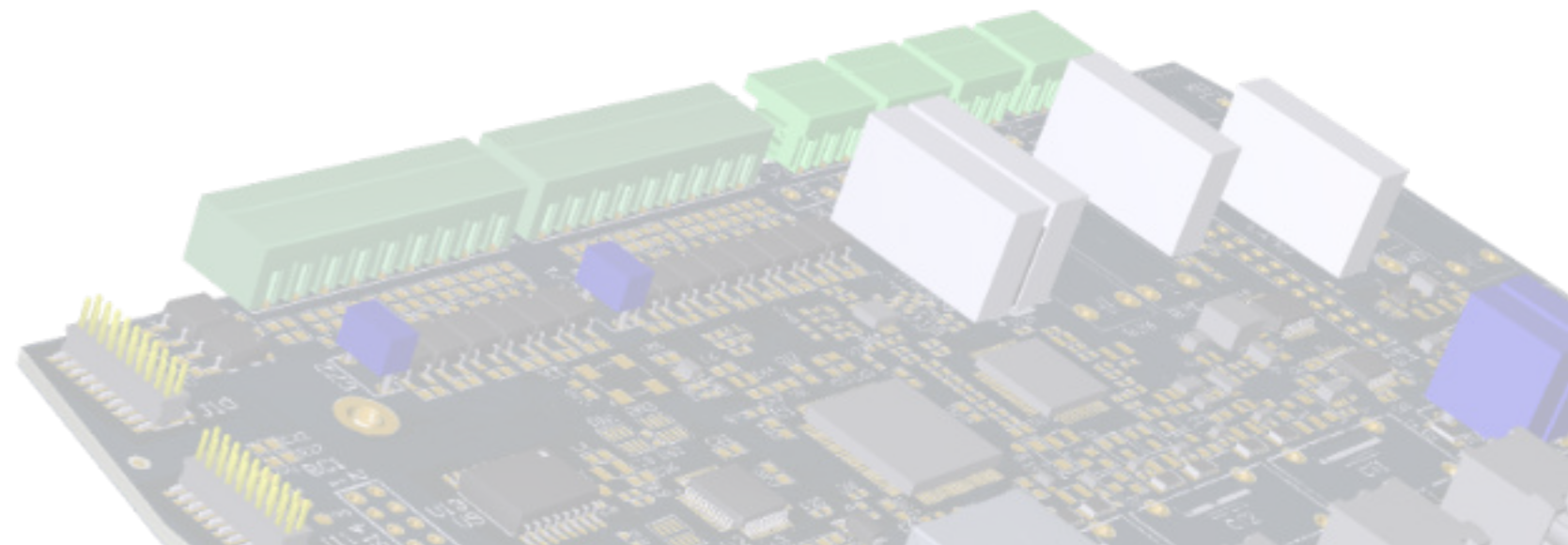

IPC versions



◆ **IPC4020exp3**

Product Code: *PT101143*

Three fault passage indicators. 16 binary inputs, 8 binary outputs. Nine phase current inputs, 1 A. Power supply 24-48 V DC.

Options: IEC 60870-5-101 master, auto-reclosing and advanced automation functions.



◆ **IPC4022**

Product Code: *PT101142*

Fault passage indicator. 8 binary inputs, 3 binary outputs. Three phase current inputs, 1 A. Power supply 24-48 V DC.

◆ **IPC4022exp2 (2 bay)**

Product Code: *PT101144*

◆ **IPC4022exp3 (3 bay)**

Product Code: *PT101145*



◆ **IPC4020exp6**

Product Code: *PT101156*

Six fault passage indicators. Up to 37 binary inputs, 22 binary outputs. Nine phase current inputs, 1 A. Power supply 24-48 V DC.

Options: IEC 60870-5-101 master, auto-reclosing and advanced automation functions.



IPS standalone FPI



The IPS family is a range of standalone fault passage indicators for overcurrent and earth faults. Different versions are available for local indication and are suitable for substations with no communication, or for use with an existing RTU that collects and transmits FPI signals to the remote control centre.

The IPS devices are designed to function maintenance-free year after year without the need for battery backup. Fault passage indication is provided by an external LED and/or relay contact. The external LED remains active for 24 hours after power is lost thanks to internal ultracapacitors. The power supply for IPS is 230 V AC.

The IPS2 FPI offers adjustable settings and faster fault indication, making it ideal for networks with distributed generation or a need for fast fault disconnection. It has interfaces for both external LED and closing relay contact.

◆ **IPS Light**

Product Code: *PT101120*

This fault detector has a flashing LED that signals a short circuit or earth fault by flashing in red. If no fault current has passed, it will flash in green. The FPI only indicates when the feeder has been disconnected. The LED is visible from outside the station, allowing identification of the faulty cable segment without the need to enter the secondary substations. The overcurrent level is 130%, while the earth fault threshold is 1 A (for CT ratio 300/1). The delay time is 60 ms..



◆ **IPS Relay**

Product Code: *PT101121*

Fault indication with closing relay contact instead of external LED. Otherwise identical to IPS Light.



◆ **IPS2**

Product Code: *PT101122*

Fault indication using both a closing contact and an LED (optional accessory). Overcurrent and earth fault settings in several steps, providing flexibility in configuring the device to match the specific requirements of the power system.



◆ **External LED unit**
Product Code: *PT606540*
LED for IPS2



Fault detection and relay protection functions	IPS Light	IPS Relay	IPS 2	IPC4022	IPC4020	IPC4020 exp3	IPC4020 exp6
Overcurrent I>	<input checked="" type="checkbox"/>	<input checked="" type="checkbox"/>	<input checked="" type="checkbox"/>	<input checked="" type="checkbox"/>	<input checked="" type="checkbox"/>	<input checked="" type="checkbox"/>	<input checked="" type="checkbox"/>
Overcurrent I>>				<input checked="" type="checkbox"/>	<input checked="" type="checkbox"/>	<input checked="" type="checkbox"/>	<input checked="" type="checkbox"/>
Earth fault directional	<input checked="" type="checkbox"/>	<input checked="" type="checkbox"/>	<input checked="" type="checkbox"/>	<input checked="" type="checkbox"/>	<input checked="" type="checkbox"/>	<input checked="" type="checkbox"/>	<input checked="" type="checkbox"/>
Earth fault non-directional				<input checked="" type="checkbox"/>	<input checked="" type="checkbox"/>	<input checked="" type="checkbox"/>	<input checked="" type="checkbox"/>
Phase break				<input checked="" type="checkbox"/>	<input checked="" type="checkbox"/>	<input checked="" type="checkbox"/>	<input checked="" type="checkbox"/>
Transient fault recorder				<input checked="" type="checkbox"/>	<input checked="" type="checkbox"/>	<input checked="" type="checkbox"/>	<input checked="" type="checkbox"/>
Fully automated fault isolation and power restoration (option)					<input checked="" type="checkbox"/>	<input checked="" type="checkbox"/>	<input checked="" type="checkbox"/>
Auto reclosing (option)				<input checked="" type="checkbox"/>	<input checked="" type="checkbox"/>	<input checked="" type="checkbox"/>	<input checked="" type="checkbox"/>
PLC function (option)					<input checked="" type="checkbox"/>	<input checked="" type="checkbox"/>	<input checked="" type="checkbox"/>
Measurements							
Phase currents, residual current	<input checked="" type="checkbox"/>	<input checked="" type="checkbox"/>	<input checked="" type="checkbox"/>	<input checked="" type="checkbox"/>	<input checked="" type="checkbox"/>	<input checked="" type="checkbox"/>	<input checked="" type="checkbox"/>
Temperature				<input checked="" type="checkbox"/>	<input checked="" type="checkbox"/>	<input checked="" type="checkbox"/>	<input checked="" type="checkbox"/>
Fault current, I>/I>>				<input checked="" type="checkbox"/>	<input checked="" type="checkbox"/>	<input checked="" type="checkbox"/>	<input checked="" type="checkbox"/>
Maximum load current				<input checked="" type="checkbox"/>	<input checked="" type="checkbox"/>	<input checked="" type="checkbox"/>	<input checked="" type="checkbox"/>
Current 15 min average				<input checked="" type="checkbox"/>	<input checked="" type="checkbox"/>	<input checked="" type="checkbox"/>	<input checked="" type="checkbox"/>
Hardware							
Current inputs	3	3	3	3	3	9	18
Binary inputs				8	16	16	22(37)
Binary outputs		1	1	3	8	8	13(22)
LED output	1		1				
Power supply							
24 - 48 VDC				<input checked="" type="checkbox"/>	<input checked="" type="checkbox"/>	<input checked="" type="checkbox"/>	<input checked="" type="checkbox"/>
230 VAC	<input checked="" type="checkbox"/>	<input checked="" type="checkbox"/>	<input checked="" type="checkbox"/>				
Service interface							
Ethernet, RJ45 10/100Base				<input checked="" type="checkbox"/>	<input checked="" type="checkbox"/>	<input checked="" type="checkbox"/>	<input checked="" type="checkbox"/>
USB type B				<input checked="" type="checkbox"/>	<input checked="" type="checkbox"/>	<input checked="" type="checkbox"/>	<input checked="" type="checkbox"/>
Communication ports							
RJ45 Ethernet 100Mb				<input checked="" type="checkbox"/>	<input checked="" type="checkbox"/>	<input checked="" type="checkbox"/>	<input checked="" type="checkbox"/>
RS485 (RS422 option)				<input checked="" type="checkbox"/>	<input checked="" type="checkbox"/>	<input checked="" type="checkbox"/>	<input checked="" type="checkbox"/>
RS232, DSUB9 DCE (option)					<input checked="" type="checkbox"/>	<input checked="" type="checkbox"/>	<input checked="" type="checkbox"/>
Communication protocol							
IEC 60870-5-101				<input checked="" type="checkbox"/>	<input checked="" type="checkbox"/>	<input checked="" type="checkbox"/>	<input checked="" type="checkbox"/>
IEC 60870-5-104				<input checked="" type="checkbox"/>	<input checked="" type="checkbox"/>	<input checked="" type="checkbox"/>	<input checked="" type="checkbox"/>
IEC 60870-5-101 Master (option)					<input checked="" type="checkbox"/>	<input checked="" type="checkbox"/>	<input checked="" type="checkbox"/>
IEC 60870-5-104 Master (option)					<input checked="" type="checkbox"/>	<input checked="" type="checkbox"/>	<input checked="" type="checkbox"/>

Current measurement



All Protrol fault passage indicators use phase current measurements for accurate fault detection. Cable transformers are mounted on the insulated cable parts in the line bays. For split-core current transformers, the detachable yoke can be removed and reattached without tools. Cable current transformers and sensors for overhead lines can be mounted on energised and non-energised conductors.

◆ Cable transformers



◆ 150/1 A
Product Code: PT606550

◆ 300/1 A
Product Code: PT606551

Opening 34 mm
Diameter 40 mm
4 m cable

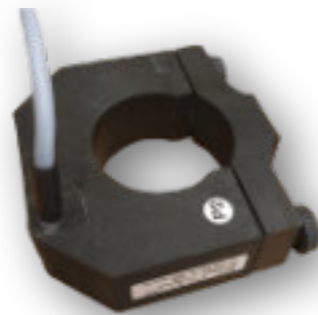

◆ 300/1 A
Product Code: PT606581

Opening 48 mm
Diameter 65 mm
8 m shielded cable



◆ LOFA

◆ 200/1 A, 12 kV
Product Code: PT606590

◆ 200/1 A, 24 kV
Product Code: PT606591

For overhead lines, the split-core current sensors can be mounted on insulated and non-insulated conductors. The locking clamp that closes the magnetic path of the current sensors fixes the sensor to the overhead line, and penetrates any insulating layer of the conductor.



Control and Monitoring



◆ PDCIO

Product Code: *PT303215*

PDCIO is used to expand the IPC devices when a large number of binary signals shall be transmitted to and from the secondary substation. Signal configuration is made using the integrated web interface of the IPC device.

◆ PxC

Product Code: *PT404330*

PxC is an isolated RS485 / RS422 interface for IEC 60870-5-101 and is jacked onto PDC2 and PDCIO.



◆ PDC2

Product Code: *PT303211*

PDC2 is a small DIN rail-mounted RTU with scalable architecture. PDC2 is easily expanded by plug-in I/O modules. It has 13 binary inputs and 8 outputs, and one Pt100. All in- and outputs have LED indications. The communication interface is IEC 60870-5-101/-104 and it has a USB service port.

Expansions:

◆ PBI

Product Code: *PT303220*

15 binary inputs

◆ PBO

Product Code: *PT303230*

12 binary outputs

◆ PAI

◆ Product Code: *PT303240*

8 analog inputs 0/4 - 20 mA

◆ Product Code: *PT303241*

4 analog inputs 0/4 - 20 mA

3 Pt100 inputs

1 voltage input +- 30 VDC



Communication



This product group includes devices for improved signal cable conditioning and protection, as well as the LoRaWAN interface for IPC402x. All products are DIN rail mounted.



◆ LSR

Product Code: *PT404310*

RS232 – 2 x RS485 modem

Product Code: *PT404311*

RS485 – 2 x RS485 repeater

LSR is a combined Modem, Line Splitter and Repeater. Several LSR units can be stacked for division into more than two transceiver networks.



◆ PxL

Product Code: *PT404520*

PxL is a communication interface for LoRaWAN in the 868 Mhz frequency band. It has a serial interface for IPC402x.

◆ OVP

Product Code: *PT606510*

OVP is an overvoltage protection device for RS485 signal cables. It reduces induced voltages and protects the signal interfaces of valuable equipment in the secondary substations.

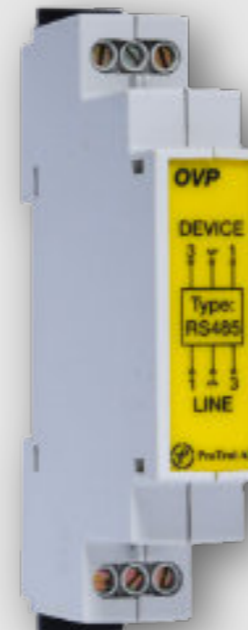

Cabinets and Solutions

Standard cabinets

- Product Code: PT715004 - IPC4020
 - Product Code: PT715005 - IPC4020exp3
 - Product Code: PT715013 - PDC2
- Polycarbonate cabinet

Dimensions: 600 x 400 x 210 mm or 700 x 500 x 300 mm

Included components:

- Product Code: PT505420 - Battery charger
- Product Code: PT505430 - Batteries 2 x 12 V, 7 A
- Product Code: PT606510 - Overvoltage protection OVP

The cabinet has a local/remote switch on the front door, zero voltage supervision relay for 230 V AC, space for modem for mobile network, terminals, fuses, bushings and ventilation.

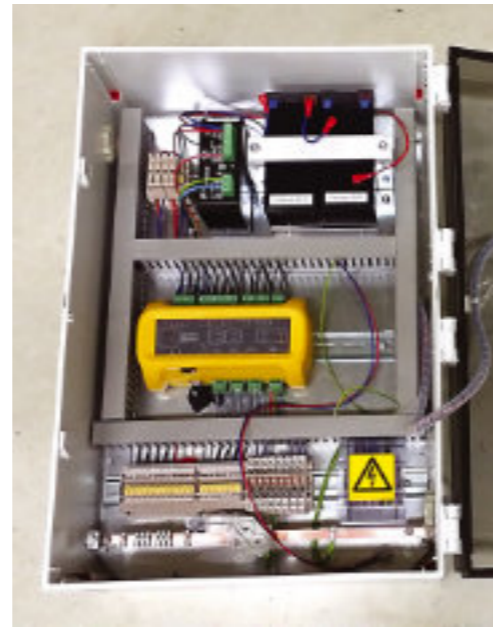

Examples of customer specific cabinets

- Outdoor stainless steel cabinet
- Backup control panel
- Battery supervision
- Additional I/O
- Heater with thermostat



List of optional additions for the cabinets:

- Rain cover
- Backup control panel
- Outdoor cabinet
- Outdoor stainless steel cabinet
- Customer specific adjustments
- Battery supervision solutions
- Super capacitor backup
- Battery discharge protection
- Additional I/O
- Integration of customer communication equipment
- Pole mounting assembly details
- Heater with thermostat

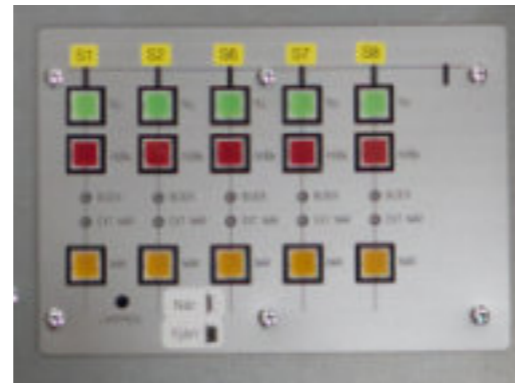

- Standalone FPI cabinet solution
- Battery backup
- Mobile communication modem
- Heater with thermostat

- Standalone FPI outdoor cabinet
- Heater with thermostat
- Rain cover







Protrol

■ PART OF ENSTO GROUP

THE COMPANY BEHIND THE TECHNOLOGY



Ensto Protrol AB
Alfagatan 3
SE-431 49 Mölndal
Sweden

✉ order@protrol.se

☎ Phone: +46 31 45 82 00

2023-05