

5DD5F 5H@GH5#@GH'C: 5DD5F 5HI G
 ?@%?cdd]b]gAXU#UddUFUHi gVcl Z5F 75'+\$) '\$ \$K 'd'Ughz+\$!) '\$!) '\$a a z:]vcl
 J A [[ZAgYb#K U" a ci bh]b ['@ ['gYhZJA? '5F 75 '%S:]vcl
 % " 2 j YfgdAbbj]b]gg_mXK#j Yfj c'UJ] Y'dfcYVWcbzF G(,) zCJ Dz*") %S\$ZDfcfc' %&
 &"": YXYHY 'rcf'c'W FHI # U' hXYHYVc'f'UbX'F HI YI dZ-d7 (\$&\$Z%\$%)(' ZDfcfc'
 ' " " " @_f]_UfY# YVWZfz587) +, ' z& '\$57 #&(J 87 Z) (\$) (&\$ZDfcfc'
 (' " " " c_U# 'Aff'ca _d'UWVUX f] 'c'WYH# 'c'WU# F Ya cY'gk]WV f'tb Vdz Yfz N6) 58&zN6) 5N5- z(gh'dvBcZn69%\$GWbYXf9'YVWV
) " " " " A cXYa z'fYj 'Uj _j bX#A cXYa 'f'i g'ca Yf]Y a L
 6% '6UHYf]#6UHYf]mz'7H+!%&@ z&I %&J z'+5\z) (\$) (' \$ZDfcfc'
 F% 'FYA# 'YUnz& 'S 57z&I ' #7Cz (\$) &,"& '\$\$\$\$ZFYA'gcWV'Y# 'YmgcWYh (\$) &-') :]bXYf

D@BH5F #H9FA #B5@G.
 L \$ZD\cYb] : 7 cbHUVMI H'(IA HI D#D'f] \$ (* %& %& f& gh'dVgt
 L %ZD\cYb] : 7 cbHUVMI H'(IA HI D#D'f] \$ (* %& %& f& gh'dVgt
 L &ZD\cYb] : 7 cbHUVMI H'(IA HI D#D'f] \$ (* %& %& f& gh'dVgt
 L' zD\cYb] : 7 cbHUVMI FH? #G!69B 'f's' '\$- '\$, * 'f] gh'dVgt
 L' zD\cYb] : 7 cbHUVMI H! FH? #G!69B 'YbXgrOX' #bX'd'UH'g'f's' '\$, \$&- L'f] gh'dVgt
 L (zD\cYb] : 7 cbHUVMI FH? #G!69B 'f's' '\$- '\$, * 'f] gh'dVgt
 L (zD\cYb] : 7 cbHUVMI H! FH? #G!69B 'YbXgrOX' #bX'd'UH'g'f's' '\$, \$&- L'f] gh'dVgt
 L (zD\cYb] : 7 cbHUVMI FH? #G!69B 'f's' '\$- '\$, * 'f] gh'dVgt
 L (zD\cYb] : 7 cbHUVMI H! FH? #G!69B 'YbXgrOX' #bX'd'UH'g'f's' '\$, \$&- L'f] gh'dVgt
 L * zD\cYb] : 7 cbHUVMI FH? #G!69B 'f's' '\$- '\$, * 'f] gh'dVgt
 L * zD\cYb] : 7 cbHUVMI H! FH? #G!69B 'YbXgrOX' #bX'd'UH'g'f's' '\$, \$&- L'f] gh'dVgt
 L + zD\cYb] : 7 cbHUVMI ?!G=f] %' %& GA_f]b [g'fUXd]]b# i g'Y'f'fa]oU'f] gh'dVgt
 L + %ZD\cYb] : 7 cbHUVMI H'(IA HI D#D'f] \$ (* %& %& f& gh'dVgt
 L + %&#&Z: 'UggA_f]b] # 'Ugg'z'gY') I &\$Z*Z 5 f'f] #j'ck 'f& gh'dVgt
 L) + %&#&Z: 'UggA_f]b] # 'Ugg'z'gY') I &\$Z*Z 5 f'f] #j'ck 'f& gh'dVgt

: ? F 6-B 8B-B; 5F # CBB97H-CBG f]bYfbU ZDf]bX]b] Uf ZAb fYgd" d]b]f] d d
 " " " " #bYfbU 'VbbYVWcbzFca 'YUW 'f'fa]oU'f] fci dL
 fDUfYI ' !C 6G 'U'U]bYfbU'F? 'Af'ca Af_HU#BCH9. 5"]bYfbU'F? 'k]fYg'UY 'bch'UVY'YXL
 Z
 L \$.%&Zf? 'fk \$) J!? Lz% %&S' a a z: fA# fYm
 L %&#&Zf? 'fk \$) J!? Lz% %&S' a a z: fA# fYm
 L %&#&Zf? 'fk \$) J!? Lz% %&S' a a z: fA# fYm
 L &%&Zf? 'fk \$) J!? Lz% %&S' a a z: fA# fYm
 L' .%& Zf? 'fk \$) J!? Lz% %&S' a a z: fA# fYm
 L (.%& Zf? 'fk \$) J!? Lz% %&S' a a z: fA# fYm
 L).%& Zf? 'fk \$) J!? Lz% %&S' a a z: fA# fYm
 L * .%&Zf? 'fk \$) J!? Lz% %&S' a a z: fA# fYm
 L +.%&Zf? 'fk \$) J!? Lz% %&S' a a z: fA# fYm
 L +.%&c'&Zf? 'fk \$) J!? Lz% %&S' a a z: fA# fYm
 L +.%&c'&Zf? 'fk \$) J!? Lz% %&S' a a z: fA# fYm
 D9zF? 'fk \$) J!? Lz% %&S' a a z: fA# fYm

%&CJ DzCj YfgdAbbj]b]gg_mXXYhi f] Af bAf 9H YfbYhUbj AbXg'
 %&CJ DzCj Yfj c'UJ] Y'dfcYVWcb]g'ca]HYX'k \Yb 9H YfbYh]g]i gYX"

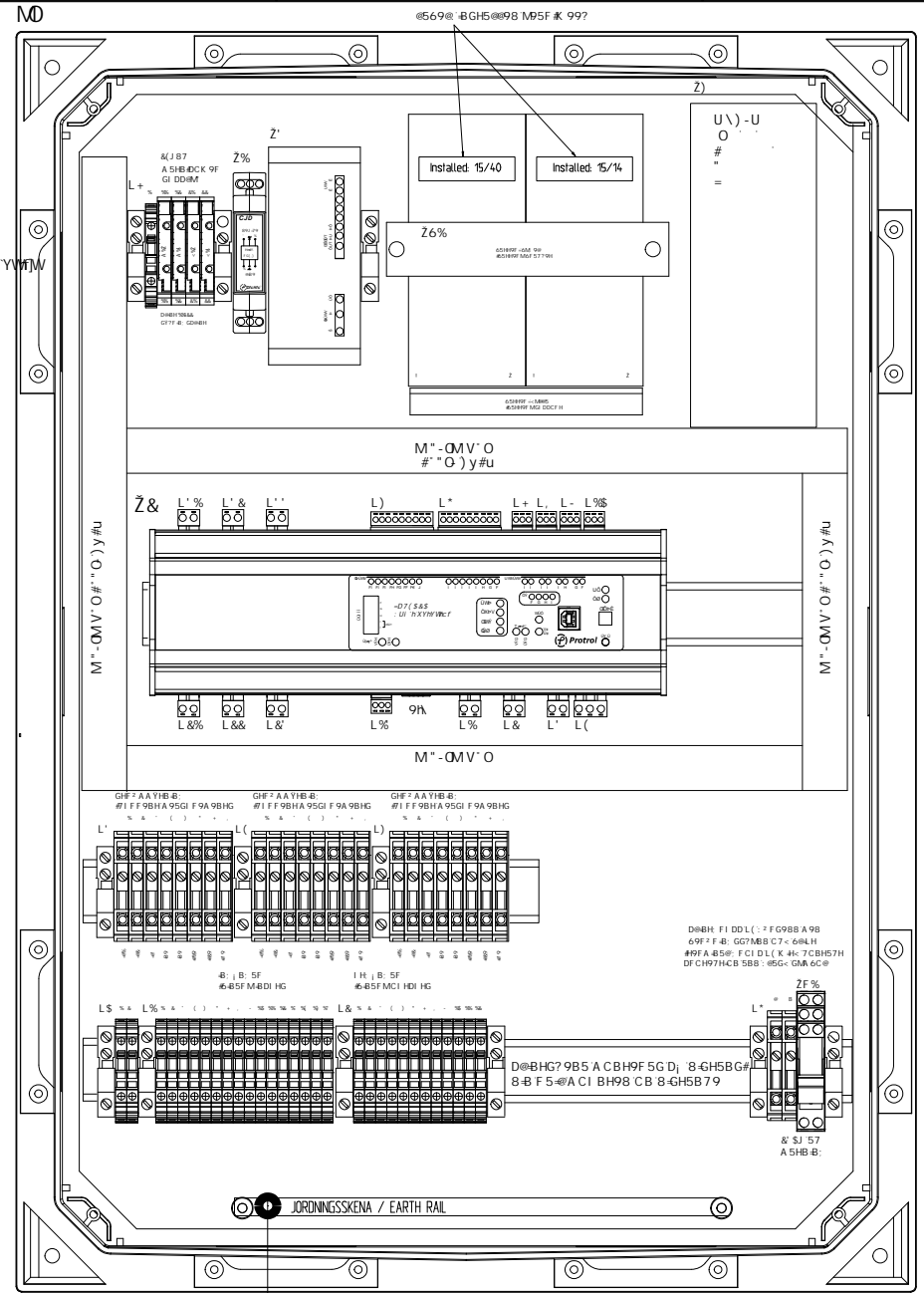

5Xt gYX cfXYf bi a VYf	6c5 '&' '&'	? CDD@B; Gq 85 #5DD5F 5HI G'6CL ?@%	@Unci h	FYj b] 6UX
@Unci h-d7 (\$&\$9LD	6c5 '\$&\$ %'		! GHubXUFX'	FYj b] 6UX
5XXYX & ['UbX Zc'f'9? @F '+l &z)	6c5 '% '(d7 (\$&\$YI d)
FYj b] b] b] b]	: c_ ; fJ'YUW	+% \$ \$)	Protrol	% \$ \$)

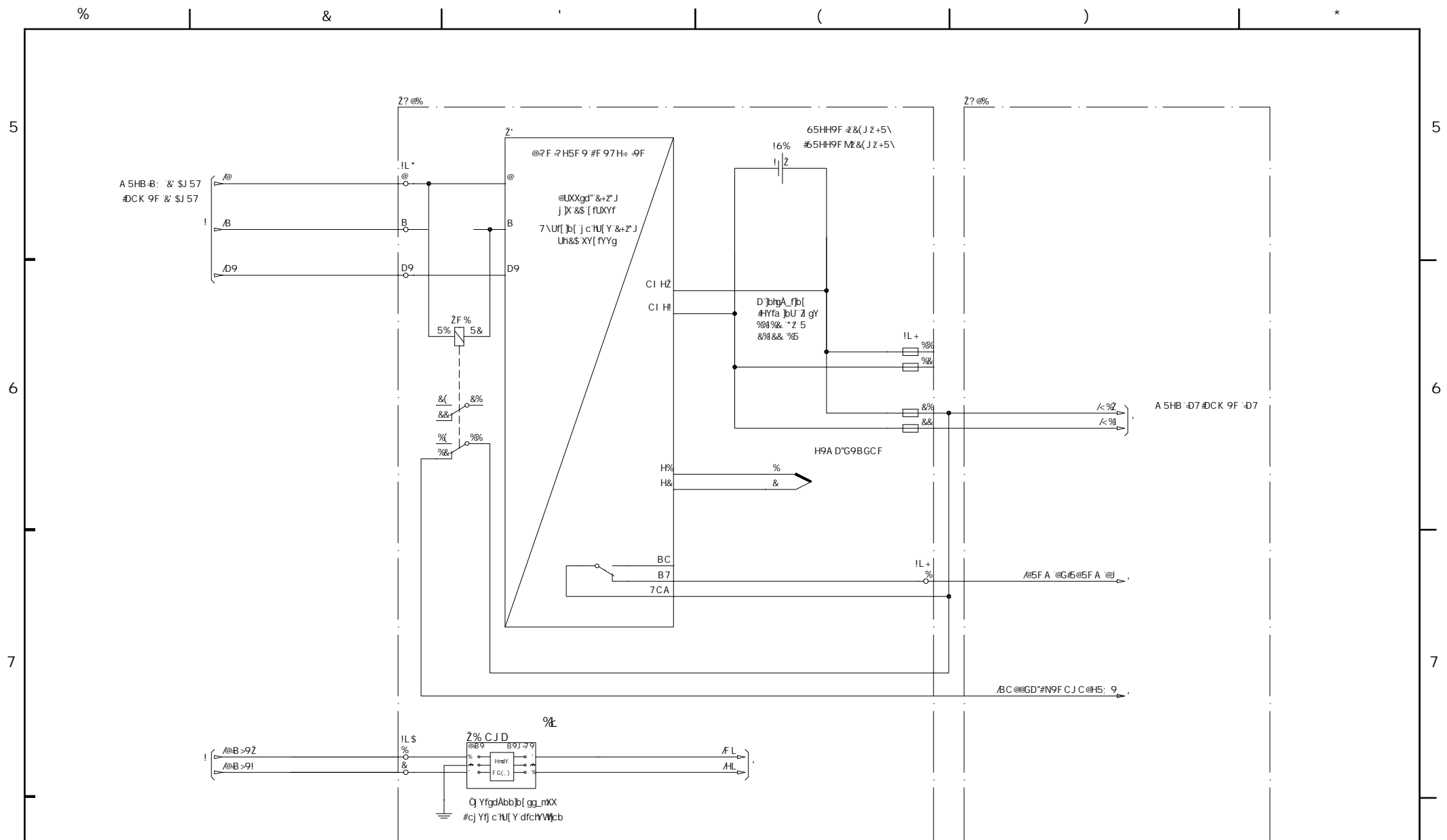

%C J Dž Qj YfgdAbb]b[gg_nXXYhi h Af' bAf' 9H YfbYhUbj AbXg"

%C J Dž c j Yfj c' hU[Y' dfchVW]cb]g' ca]H YX' k \ Yb' 9H YfbYH'

* 5Xt gYX c fXYf bi a VYf	6c5 ' & ' & ' ' .	? CDD@B: G@ 85 #5DD5F5HI G'6CL '? @%	8Ygl b WYVYX Vm A A	? fYhgWYa U#]fV]h8]U[fUa	FYj]b G VYh
) 7\Ub[YX' gcWYhbi a VYf	6c5 '& \$' & ' .	Đ7 (\$&YI d	8fuk]b[WYVYX Vm H?	! GHUbXUX'	FYj]b G VYh
% 5Xt gYX C J D	6c5 '% (.	+% \$ \$)	8fuk b Vm 6c5	(P) Protrol	* G VYh
FYj]b G VYh	5ddX MUFK YY			8Ydh ; 6; MUFK YY % % \$) %	* G VYh & 7cb

GH! & \$ % ! \$ & ' ? G
+ % \$ \$)

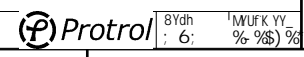

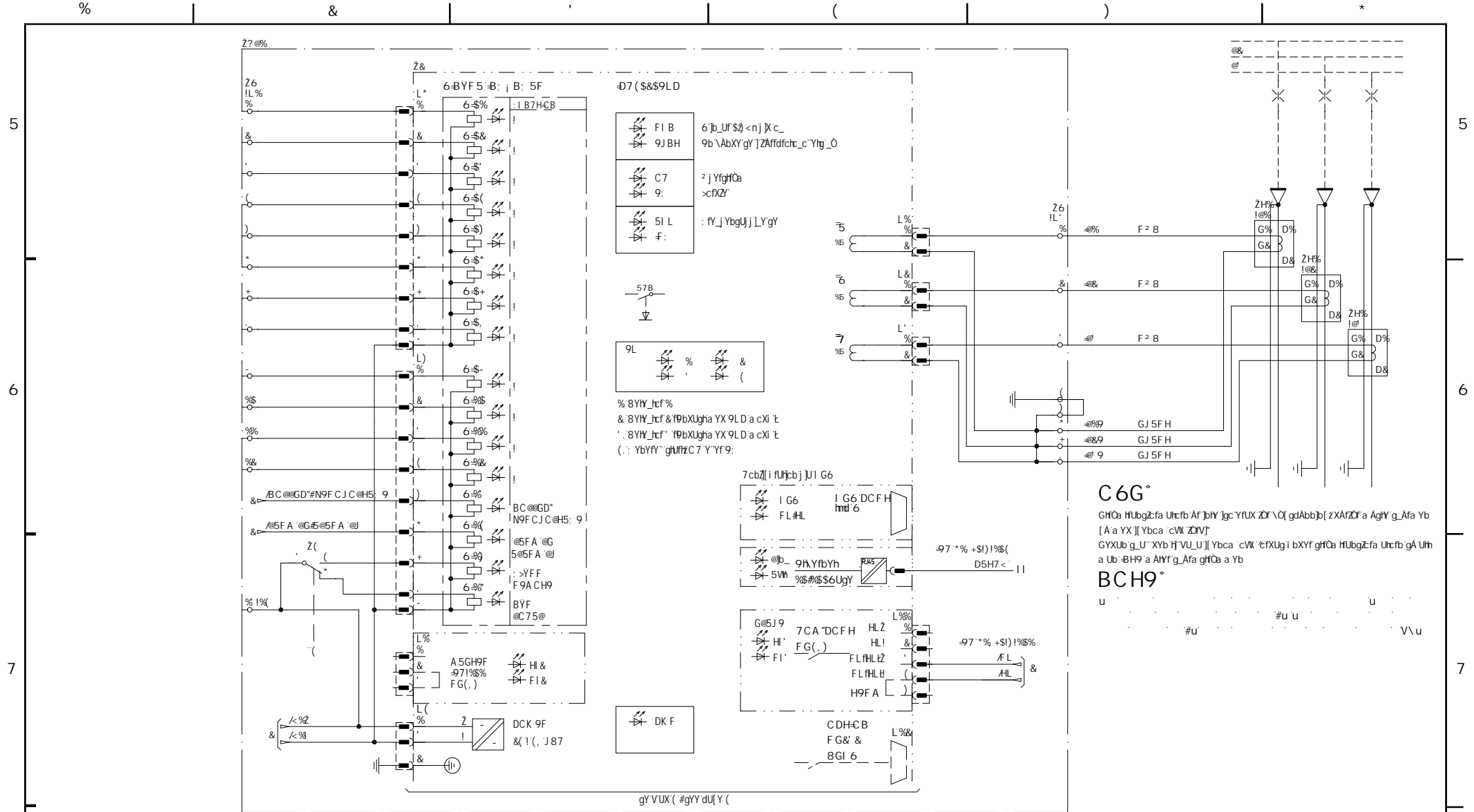

5X1 ghYX cFYf bi a VYf	6c5	& ' &	8Ygl b WYVYX Vm A A	? fYggWY a U#7]WV]h8]U[fUa	FYj b GYYh
5X1 gh7H	6c5	& \$' &	8fuk b] WYVYX Vm H?	! GHUbXUX'	FYj b GYYh
5XXYX cdhcb F G &	6c5	% ' * *	8fuk b Vm		* 7cbh
FYj b FYj jcb	5ddX	MUFK YY_ + % \$ \$)	6c5	((

GH!&\$% ! \$& ? G
+ % \$ \$)

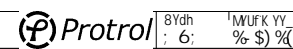

8Ydh 1 MUFK YY_ % \$) %
; 6;

5

6

7

8

5

6

7

8

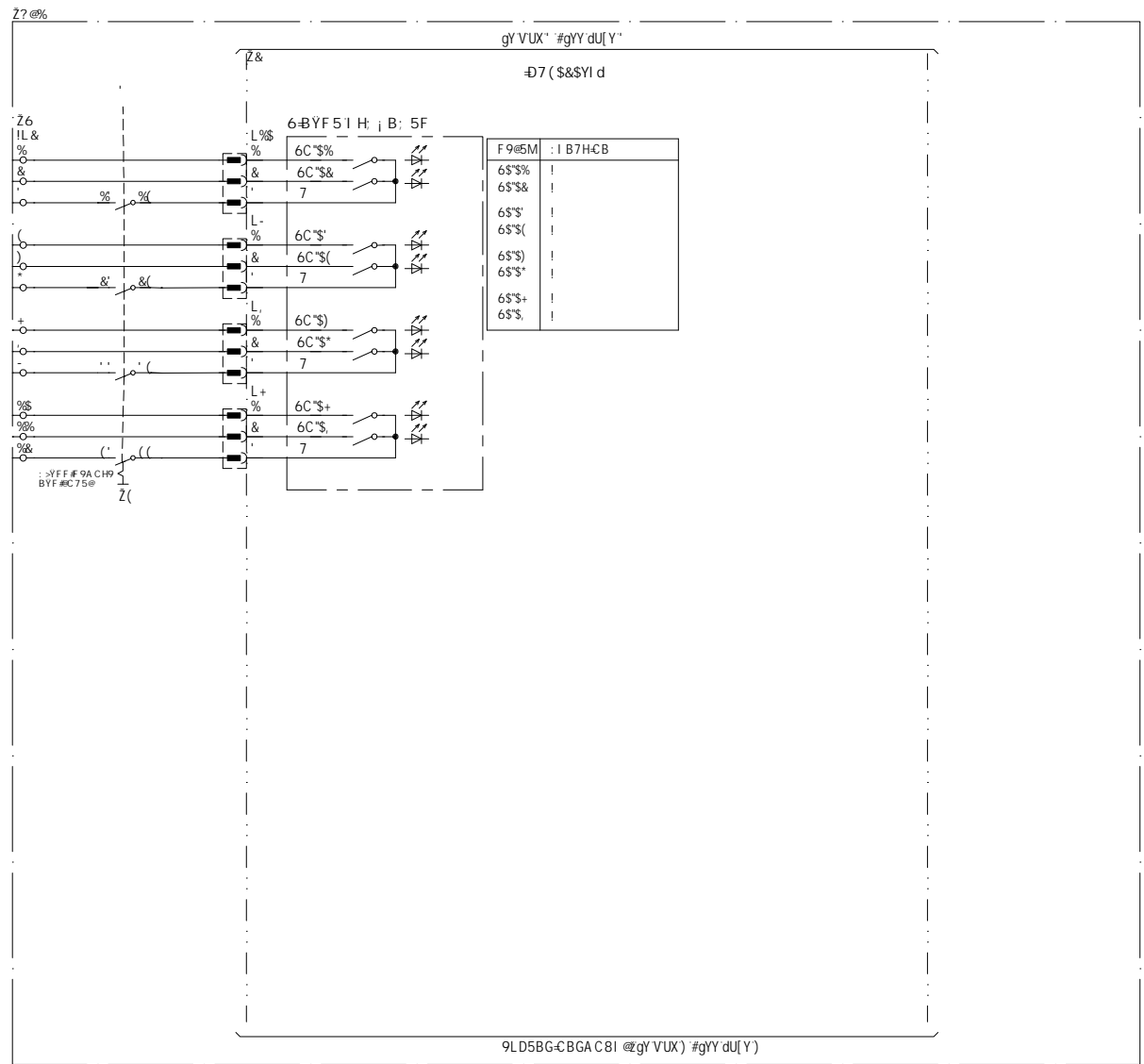

				8Ygl b WYVYX Vm A A		? fYtggWYa U#7 JfW Jh8 JU[fUa		FYj b GYYh	
		? CDD@B: G@ 85 #5DD5F 5HI G'6CL '? @%		8fuk b WYVYX Vm H?		GHUbXUFX'		FYj b GYYh	
% 5X† gYX cFYf bi a Vyf		6c5 & '&		8fuk b Vm 6c5		GHUbXUFX'		GH!&\$% ! \$& ? G	
FYj b FYj jcb		5ddX MUFK YY_ +% \$\$)				Protrol 8Ydh 1 MUFK YY_ % \$) %		+ % \$ \$)	

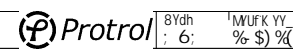

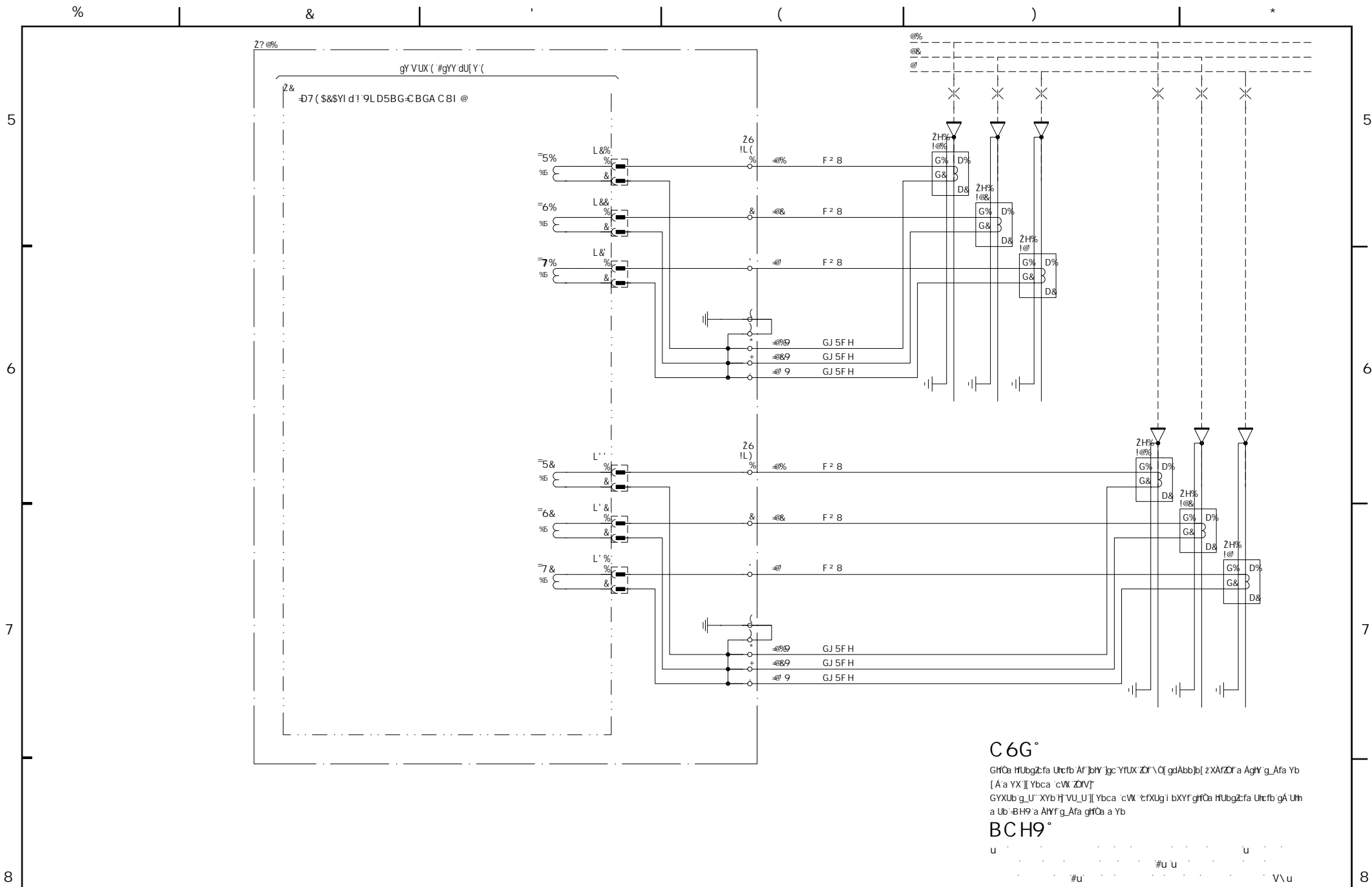

C 6G°

GfOa fUbgzfa Urefb Af jhV jgc YfUX Zf\Q gdAbb|b| zXfZf'a AgHf_g_Afa Yb
 [A:a YX] Ybca 'cW ZfVf
 GYXUb_g_U'XYb f'VU_U Ybca 'cW' cfXUg'i bXYf gffOa fUbgzfa Urefb gA UH
 a Ub -BH9'a AYf_g_Afa gffOa a Yb

BCH9°

u #u u u #u u V u u

8Yg b WYVYX Vm A A	? fYfgWYa U# JfW Jh8 JU[fUa	FVj } (VYVh
8fUk b WYVYX Vm H?	! GHUbXufX	FVj } (VYVh
8fUk b Vm 6c5	8Ydh ; 6; MUFK YY % \$) %	* (VYVh) 7cbh !
5X1 ghcXYfbi a Wf 6c5 & ' &	? CDD@B; Gq 85 #5DD5F 5HI G'6CL ? @%	GHI &\$% !&\$? G
) 5X1 gh7H 6c5 &S &	#D7 (\$&\$YI d	+% \$ \$)
FVj } b FVj jkb 5ddX MUFK YY_ +%	+% \$ \$)	